

1260 VXI SWITCHING CARD

1260-54 TREE MULTIPLEXER MODULE

PUBLICATION NO. 980673-009

RACAL INSTRUMENTS

Racal Instruments, Inc.

4 Goodyear St., Irvine, CA 92618-2002
Tel: (800) RACAL-ATE, (800) 722-2528, (949) 859-8999; FAX: (949) 859-7139

Racal Instruments, Ltd.

480 Bath Road, Slough, Berkshire, SL1 6BE, United Kingdom
Tel: +44 (0) 1628 604455; FAX: +44 (0) 1628 662017

Racal Systems Electronique S.A.

18 Avenue Dutartre, 78150 LeChesnay, France
Tel: +33 (1) 3923 2222; FAX: +33 (1) 3923 2225

Racal Systems Elettronica s.r.l.

Strada 2-Palazzo C4, 20090 Milanofiori Assago, Milan, Italy
Tel: +39 (0)2 5750 1796; FAX: +39 (0)2 5750 1828

Racal Elektronik System GmbH.

Technologiepark Bergisch Gladbach, Friedrich-Ebert-Strasse, D-51429 Bergisch Gladbach, Germany
Tel.: +49 2204 8442 00; FAX: +49 2204 8442 19

Racal Australia Pty. Ltd.

3 Powells Road, Brookvale, NSW 2100, Australia
Tel: +612 9936 7000, FAX: +612 9936 7036

Racal Electronics Pte. Ltd.

26 Ayer Rajah Crescent, 04-06/07 Ayer Rajah Industrial Estate, Singapore 0513.
Tel: +65 7792200, FAX: +65 7785400

Racal Instruments, Ltd.

Unit 5, 25F., Mega Trade Center, No 1, Mei Wan Road, Tsuen Wan, Hong Kong, PRC
Tel: +852 2405 5500, FAX: +852 2416 4335

<http://www.racalstruments.com>



PUBLICATION DATE: April 3, 2001

Copyright 2001 by Racal Instruments, Inc. Printed in the United States of America. All rights reserved.
This book or parts thereof may not be reproduced in any form without written permission of the publisher.

WARRANTY STATEMENT

All Racal Instruments, Inc. products are designed and manufactured to exacting standards and in full conformance to Racal's ISO 9001 procedures.

For the specific terms of your standard warranty, or optional extended warranty or service agreement, contact your Racal customer service advisor. Please have the following information available to facilitate service.

1. Product serial number
2. Product model number
3. Your company and contact information

You may contact your customer service advisor by:

E-Mail:	Helpdesk@racalstruments.com	
Telephone:	+1 800 722 3262	(USA)
	+44(0) 8706 080134	(UK)
	+852 2405 5500	(Hong Kong)
Fax:	+1 949 859 7309	(USA)
	+44(0) 1628 662017	(UK)
	+852 2416 4335	(Hong Kong)

RETURN of PRODUCT

Authorization is required from Racal Instruments before you send us your product for service or calibration. Call your nearest Racal Instruments support facility. A list is located on the last page of this manual. If you are unsure where to call, contact Racal Instruments, Inc. Customer Support Department in Irvine, California, USA at 1-800-722-3262 or 1-949-859-8999 or via fax at 1-949-859-7139. We can be reached at:

helpdesk@racalstruments.com.

PROPRIETARY NOTICE

This document and the technical data herein disclosed, are proprietary to Racal Instruments, and shall not, without express written permission of Racal Instruments, be used, in whole or in part to solicit quotations from a competitive source or used for manufacture by anyone other than Racal Instruments. The information herein has been developed at private expense, and may only be used for operation and maintenance reference purposes or for purposes of engineering evaluation and incorporation into technical specifications and other documents which specify procurement of products from Racal Instruments.

FOR YOUR SAFETY

Before undertaking any troubleshooting, maintenance or exploratory procedure, read carefully the **WARNINGS** and **CAUTION** notices.

This equipment contains voltage hazardous to human life and safety, and is capable of inflicting personal injury.

If this instrument is to be powered from the AC line (mains) through an autotransformer, ensure the common connector is connected to the neutral (earth pole) of the power supply.

Before operating the unit, ensure the conductor (green wire) is connected to the ground (earth) conductor of the power outlet. Do not use a two-conductor extension cord or a three-prong/two-prong adapter. This will defeat the protective feature of the third conductor in the power cord.

Maintenance and calibration procedures sometimes call for operation of the unit with power applied and protective covers removed. Read the procedures and heed warnings to avoid “live” circuit points.

Before operating this instrument:

1. Ensure the instrument is configured to operate on the voltage at the power source. See Installation Section.
2. Ensure the proper fuse is in place for the power source to operate.
3. Ensure all other devices connected to or in proximity to this instrument are properly grounded or connected to the protective third-wire earth ground.

If the instrument:

- fails to operate satisfactorily
- shows visible damage
- has been stored under unfavorable conditions
- has sustained stress

Do not operate until performance is checked by qualified personnel.

This page was left intentionally blank.

NOTE FOR SYSTEMS WITH 1260-OPT 01T

The “Module-Specific Syntax” section of this manual shows the command syntax for the 1260-01S Smart Card. If you are using the newer 1260-01T Smart Card, the commands will NOT work as shown.

Consult the 1260-01T Manual for a description of the commands that may be used with the 1260-01T Smart Card.

The channel numbers described in this manual are valid for the 1260-01T. The channel numbers continue to be used for the 1260-01T.

The syntax of the commands that use channel numbers has changed for those cards controlled by the 1260-01T.

The new syntax used to close a channel is:

```
CLOSE (@ <module address> ( <channel> ) )
```

For example, for a relay module whose <module address> is set to 7, closing <channel> 0 is performed with the command:

```
CLOSE (@7 (0))
```

Using the older 1260-01S, the command would be (as shown in this manual):

```
CLOSE 7.0
```

Many other command syntax differences exist. Please consult chapter 2 of the 1260-01T manual for a description of the commands that are available for the 1260-01T.

Control Information for the 1260-54

The following information describes the control-register-to-relay-channel mapping for a 1260-54 Relay Module. This information may be used to control a 1260-54 when using a 1260-01T in the register-based mode of operation.

A channel within each 1x4 MUX may be selected by programming either 1 or 2 Control Registers. Selecting one channel in each MUX will open all others in that MUX.

Each Control Register is located 2 addresses from the previous Control Register. That is, each Control Register is located at an odd address. This is shown in Table 2-2 of the 1260-01T manual. Control Register 0 is located at the "Base A24 Address" for the module. Consult the "Register-Based Operation" Section of Chapter 2 of the 1260-01T manual for a description of calculating control register addresses.

Each Control Register may also control several different MUXes. For this reason it is necessary to form the new Control Register values by performing the following steps:

- Read the present Control Register values
- Invert the Control Register value (the hardware inverts the present value on reading)
- AND the present data with an AND mask from the table below
- OR the present data with the OR mask from the table below.

For example, from the table below, to select channel 10 (MUX #1, channel 0 to COM), we must write to both Control Register #0 and Control Register #1. The Control Register #0 AND mask is 3F (hexadecimal), while the Control Register #1 AND mask is F0 (hexadecimal). Similarly, the Control Register #0 OR mask is 40 (hexadecimal), while the Control Register #1 OR mask is 0C (hexadecimal). Therefore, to select channel 10, perform the following sequence of operations:

- Read the present value of Control Register #0
- Perform a 1's complement (invert) of each of the bits of this register
- AND the value with 3F hexadecimal, clearing the most significant 2 bits
- OR the value with 40 hexadecimal
- Write the value just created back to Control Register #0
- Read the present value of Control Register #1
- AND the value with F0 hexadecimal, clearing the least significant 4 bits
- OR the value with 0C hexadecimal
- Write the value just created back to Control Register #1

In 'C', this can be represented (using ViIn8() and ViOut8() to write) as follows:

```
ViAddr control_reg_0, control_reg_1;
ViUInt8 creg0_val, creg1_val;
ViStatus error;
ViSession hdl;          /* this is from the viOpen() function */

control_reg_0 = (module address of card x 0x400) + 1;
control_reg_1 = control_reg_0 + 2;

error = ViIn8(hdl, control_reg_0, &creg0_val);
creg0_val = ~ creg0_val;          /* invert the data read back */
creg0_val &= 0x3F;                /* AND with 3F hex */
creg0_val |= 0x40;                /* OR with 40 hex */
error = viOut8(hdl, control_reg_0, creg0_val);

error = ViIn8(hdl, control_reg_1, &creg1_val);
creg1_val = ~ creg1_val;          /* invert the data read back */
creg1_val &= 0xF0;                /* AND with F0 hex */
creg1_val |= 0x0C;                /* OR with 0C hex */
error = Out8(hdl, control_reg_1, creg1_val);
```

Note that for each MUX, using a value of 0 for the OR mask for all Control Registers used for that MUX will open ALL 4 channels of that MUX.

The table below shows the mapping from logical channels to control bits. The logical channels are used when operating the relay module in message-based mode. The control bits within the Control Registers are used to operate the module in register-based mode. The table shows holds one or two entries, showing the Control Register, the AND mask, and the OR mask to use to select the desired MUX relay closures.

Channel	Control Register	AND Mask (hex)	OR Mask (hex)
00	0	C0	31
01	0	C0	22
02	0	C0	14
03	0	C0	08
10	0 1	3F F0	40 0C
11	0 1	3F F0	80 08
12	0 1	3F F0	00 05
13	0 1	3F F0	00 02
20	1 2	0F FC	10 03
21	1 2	0F FC	20 02
22	1 2	0F FC	40 01
23	1 2	0F FC	80 00
30	2	03	C4
31	2	03	88
32	2	03	50
33	2	03	20
40	3	C0	31
41	3	C0	22
42	3	C0	14
43	3	C0	08
50	3 4	3F F0	40 0C
51	3 4	3F F0	80 08
52	3 4	3F F0	00 05
53	3 4	3F F0	00 02

Table of Contents

Chapter 1	
INTRODUCTION	1-1
1260-54 1GHz Tree Multiplexer Module	1-1
Specifications	1-2
Chapter 2	
INSTALLATION INSTRUCTIONS.....	2-1
Unpacking and Inspection	2-1
Reshipment Instructions	2-1
Option 01 Installation.....	2-1
Module Installation.....	2-1
Chapter 3	
MODULE SPECIFIC SYNTAX.....	3-1
1260-54 Commands	3-1
Syntax	3-1
OPEN	3-1
CLOSE	3-2
PSETUP	3-2
PDATAOUT	3-2
Chapter 4	
DRAWINGS.....	4-1
Chapter 5	
PARTS LIST	5-1
Chapter 6	
OPTIONAL HARNESS ASSEMBLIES	6-1

Chapter 7

PRODUCT SUPPORT.....	7-1
Product Support	7-1
Reshipment Instructions.....	7-1
Support Offices	7-2

List of Figures

Figure 1-1, 1260-54	1-1
Figure 1-2, 1260-54 Functional Diagram.....	1-2
Figure 1-3, 1260-54 Front Panel	1-4

This page was left intentionally blank.

Chapter 1

INTRODUCTION

1260-54 1GHz Tree Multiplexer Module

The 1260-54 provides six 1 x 4 tree multiplexers. Each channel has the capability of being terminated into an optional 50Ω SMB terminator.

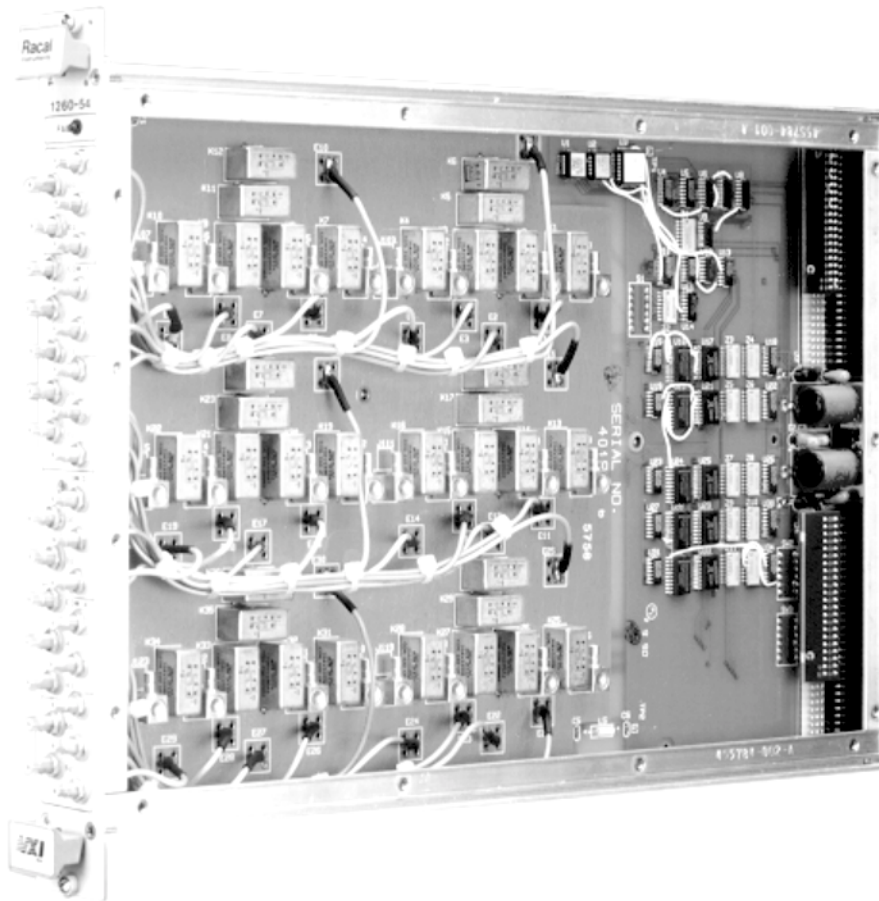

Figure 1-1, 1260-54

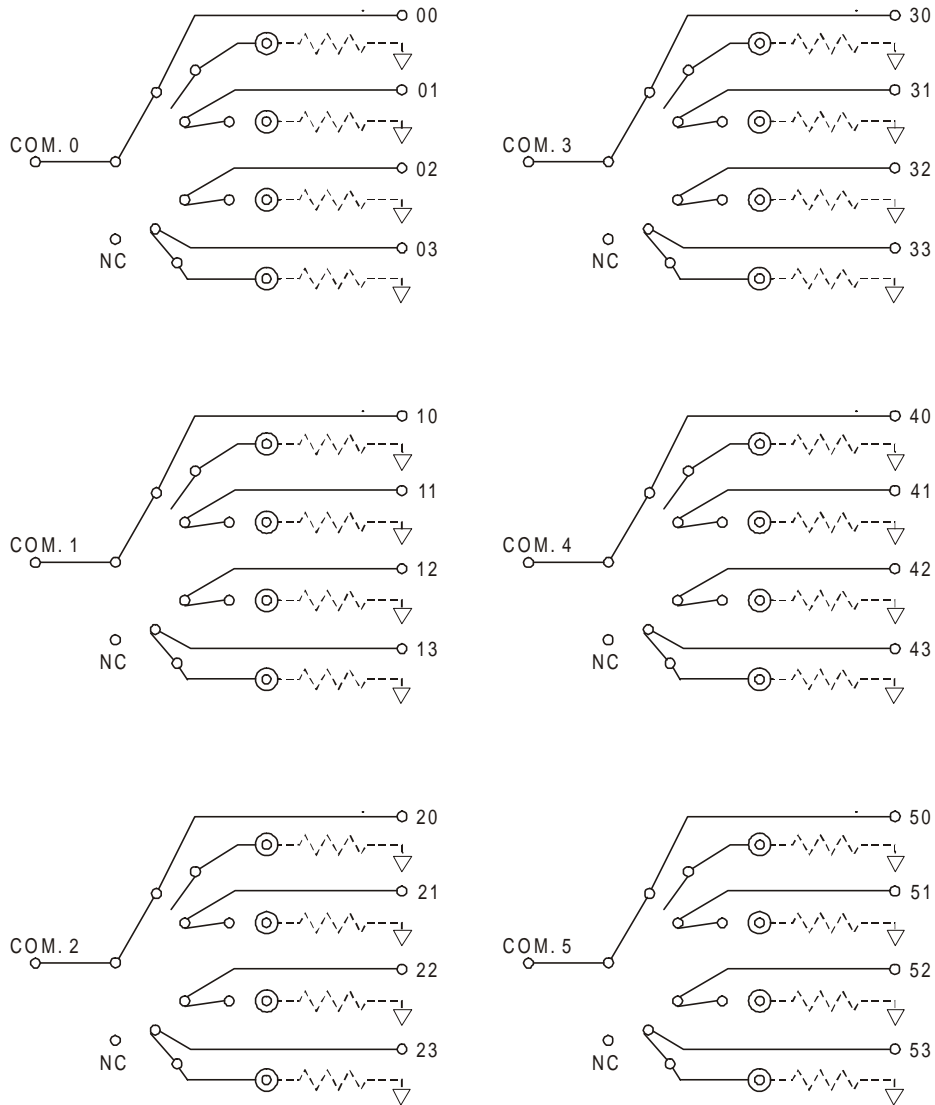

Figure 1-2, 1260-54 Functional Diagram

Specifications

Minimum Option 01 Firmware Revision	17.1
User Connector	SMC Caution: Mating Connector engagement should not exceed 16in. oz. Torque maximum.
Maximum Switchable Voltage (Signal to Ground)	30VDC, 100VAC RMS

Maximum Switchable Current Per Channel	1.5ADC, 1.5A RMS
Maximum Switchable Power Per Channel	60W DC, 60VA AC, 60W RF Power
DC Performance	
Path Resistance	<1 Ω
AC Performance	
Bandwidth, (-3 dB, 50 Ω Termination)	1.3 GHz
Insertion Loss, (50 Ω Termination)	<.50dB at 100MHz <1.5dB to 500 MHz <2.0dB to 1GHz
Crosstalk Across Groups (50 Ω Termination)	<-100dB to 100MHz <-80dB to 500MHz <-60dB to 1GHz <-50dB to 1.3GHz
Isolation Between Channels (50 Ω Termination)	<-80dB at 100MHz <-65dB at 500MHz <-55dB at 1GHz <-40dB at 1.3GHz
VSWR (50 Ω Termination)	1.1:1 at 100MHz 1.25:1 at 500MHz 1.75:1 at 1GHz 1.75:1 at 1.3GHz
Switching Time	<10mS
Cooling Requirements	
Airflow	4 litres/sec
Backpressure	0.5mmH ₂ O
Power Requirements (I_{pm})	
+5 V	0.4A (2.8A with Option 01)
+12 V	10 mA per relay
Weight	1.17 Kg (2.59 lb) without Option 01 1.29 Kg (2.87 lbs) with Option 01

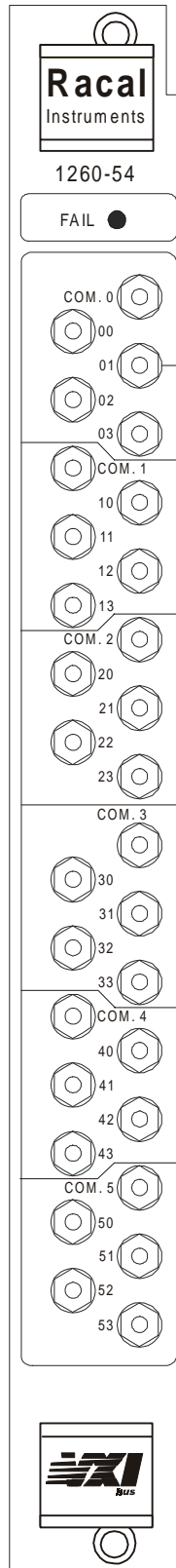

Figure 1-3, 1260-54 Front Panel

Chapter 2

INSTALLATION INSTRUCTIONS

Unpacking and Inspection

1. Before unpacking the switching module, check the exterior of the shipping carton for any signs of damage. All irregularities should be noted on the shipping bill.
2. Remove the instrument from its carton, preserving the factory packaging as much as possible.
3. Inspect the switching module for any defect or damage. Immediately notify the carrier if any damage is apparent.
4. Have a qualified person check the instrument for safety before use.

Reshipment Instructions

1. Use the original packing when returning the switching module to Racal Instruments for calibration or servicing. The original shipping carton and the instrument's plastic foam will provide the necessary support for safe reshipment.
2. If the original packing is unavailable, wrap the switching module in plastic sheeting and use plastic spray foam to surround and protect the instrument.
3. Reship in either the original or a new shipping carton.

Option 01 Installation

Installation of the Option 0 1 into the 1260-54 is described in the Installation section of the 1260 Series VXI Switching Cards Manual.

Module Installation

Installation of the 1260-54 Switching Module into a VXI mainframe, including the setting of DIP switches, is described in the Installation section of the 1260 Series VXI Switching Cards Manual. The ID byte DIP switches, SW1-5 and SW 1-6, should be set OFF.

MODULE SPECIFIC SYNTAX

1260-54 Commands

The 1260-54 RF Multiplexer supports the OPEN, CLOSE, PSETUP, RESET and PDATAOUT commands.

NOTE

The 1260-54 Coaxial switching module is supported by the Option 01 Operating Systems at Revision levels 3.1 and above.

Syntax

The module specific syntax for the 1260-54 RF Multiplexer is as follows:

OPEN

OPEN <module address>.<channel>[;<module address>.<channel>]

where <module address> is the address.

<channel> is the relay to be closed to connect an input to the output.

Note that Channels remain closed until opened by an OPEN command.

The range of values for <channel> is:

00-03
10-13
20-23
30-33
40-43
50-53

CLOSE

The Module Specific Syntax for the CLOSE command is the same as for the OPEN command. Note each group of <channel> values contains five values. Using the highest value in each group, 04, 14, 24 etc, will give a connection to a "not connected" pin, i.e., open the path from input to output. This has the same effect using an OPEN command.

Connections between input and output are mutually exclusive within a group in the switch module. A CLOSE command will open an existing connection and close the new connection. An OPEN command will open any existing connection in the group and open circuit the Common connection.

The 1260-54 is restricted to the Break-Before-Make sequence mode.

PSETUP

The PSETUP command causes the specified module setup to be transmitted to the VXI Controller. The syntax used is:

PSETUP <module address>[;<module address>][;<module address>] where <module address> is the address.

The responses to the PSETUP command for the 1260-54 multiplexer is as follows:

```
<module address>. 1260-54 COAXIAL SWITCHING MODULE
<module address>.BBM
<module address>.END
```

PDATAOUT

The PDATAOUT command causes the specified module to transmit the CLOSED state of the relays fitted to the switching module to the 1260 Controller. The syntax used is:

PDATAOUT <module address>[.<module address>] [;<module address>]

The responses to the PDATAOUT command is as follows:

```
<module address>.1260-54 RF MULTIPLEXER
<module address>.<channel>[,<channel>] [,<channel>]
<module address>.END
```

The range of values for <channel> is:

00-03,10- 13,20-23,30-33,40-43 and 50-53.

Note that connections to the "not connected" pins within a group

are not displayed.

This page was left intentionally blank.

Chapter 4

DRAWINGS

404768, Final Assembly, 1260-54 4-3

401908, PCB Assy, 1260-54 4-4

431908, Schematic, 1260-54..... 4-6

This page was left intentionally blank.

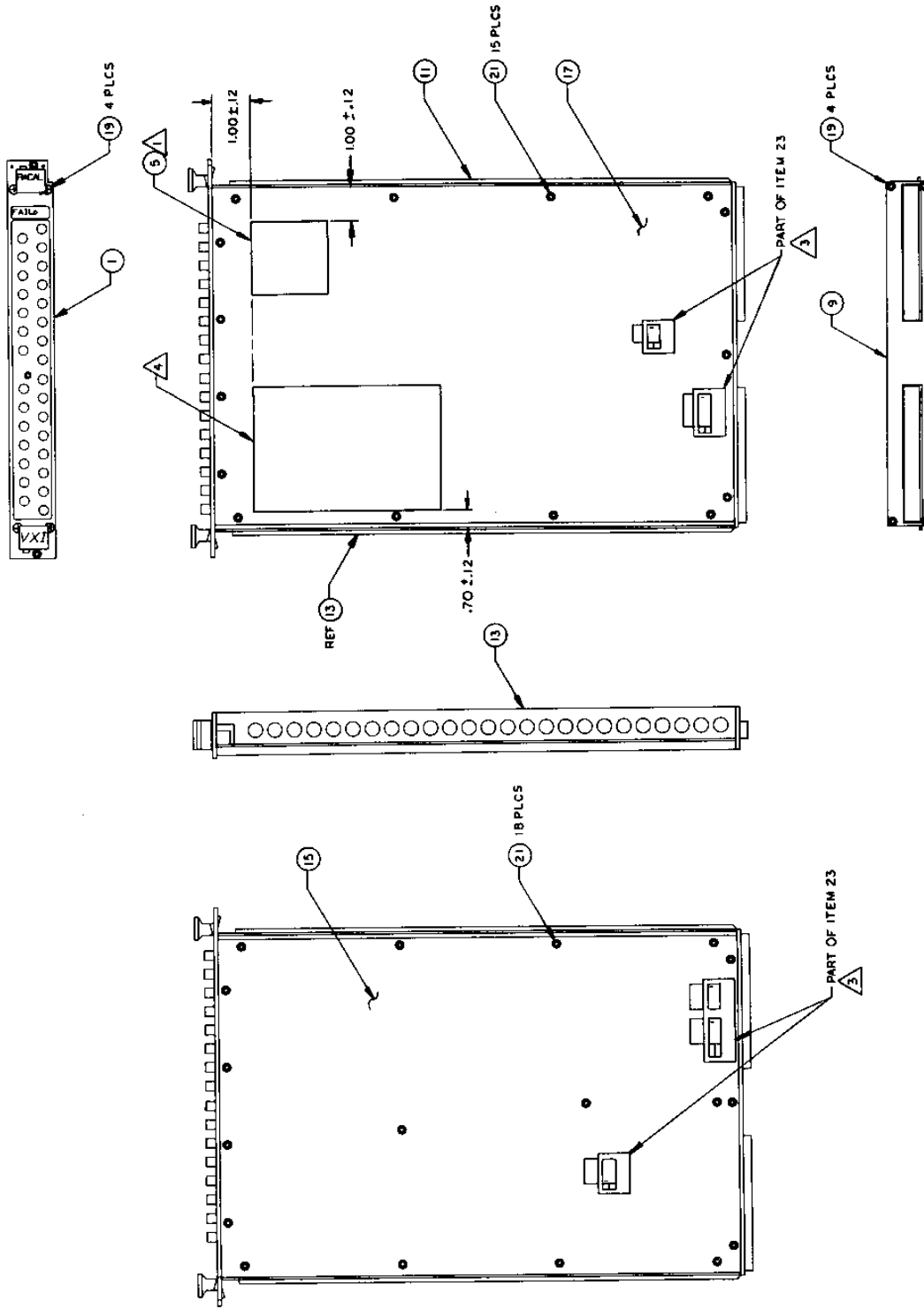

- 4 LOCATE APPROPRIATE VXI LABEL WHERE SHOWN. REFERENCE 921410 FOR SPECIFIC LABEL INFORMATION.
 - 5 AFFIX LABELS AS SHOWN, ALIGN LABEL TEXT WITH APPROPRIATE SWITCH ACTUATORS.
 - 2. INCLUDE ITEM 3 (SHIPPING KIT) IN BOX WITH ASSY.
 - 3 LOCATE LABEL (ITEM 5) AS SHOWN.
- NOTES UNLESS OTHERWISE SPECIFIED

PROPRIETARY NOTICE
 THIS DOCUMENT AND THE TECHNICAL DATA HEREIN DISCLOSED ARE PROPRIETARY TO RACAL INSTRUMENTS INC. NO PERMISSION OF RACAL INSTRUMENTS INC. IS TO BE GIVEN FOR REPRODUCTION OR USE IN ANY MANNER WITHOUT THE WRITTEN PERMISSION OF RACAL INSTRUMENTS INC. THIS DOCUMENT IS NOT TO BE USED FOR THE MANUFACTURE OF ANY PRODUCT OR SERVICE THAT IS A COMPETITIVE SOURCE OR USED FOR THE REPRODUCTION OF ANY PRODUCT OR SERVICE THAT HAS BEEN DEVELOPED AT PRIVATE EXPENSE, AND MAY BE USED FOR RESEARCH AND DEVELOPMENT PURPOSES ONLY. RACAL INSTRUMENTS INC. ACCEPTS NO LIABILITY FOR DAMAGES OF ANY KIND ARISING FROM THE USE OF THIS DOCUMENT OR THE PRODUCTS FROM RACAL INSTRUMENTS INC.

Racal Instruments, Inc.			
4. Goodyear St., Irvine, CA. 92718-2002			
DOCUMENT TITLE			
FINAL ASSY, 1260-54			
SIZE	CODE IDENT NO.	DOCUMENT NO.	REV.
D	21793	404768	D
SCALE			SHEET 1 OF 2

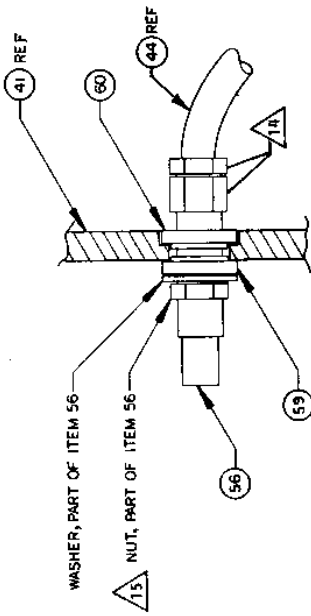

DETAIL A
SCALE: NONE
30 PLUS

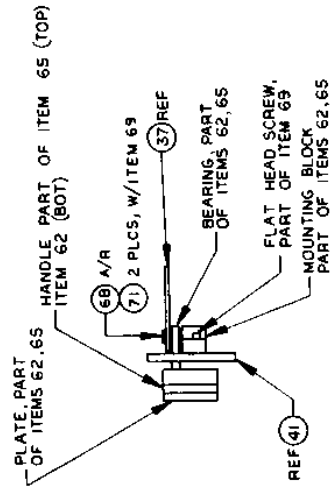

DETAIL B
SCALE: NONE

PROPRIETARY NOTICE
THIS DOCUMENT AND THE TECHNICAL DATA HEREIN DISCLOSED ARE PROPRIETARY TO RACAL INSTRUMENTS, INC. NO PART OF THIS DOCUMENT IS TO BE REPRODUCED, COPIED, EITHER WHOLLY OR IN PART, OR TRANSMITTED IN ANY FORM OR BY ANY MEANS, ELECTRONIC OR MECHANICAL, INCLUDING PHOTOCOPYING, RECORDING, OR BY ANY INFORMATION STORAGE AND RETRIEVAL SYSTEM, WITHOUT THE WRITTEN PERMISSION OF RACAL INSTRUMENTS, INC. ANY UNAUTHORIZED REPRODUCTION OR DISCLOSURE OF THIS DOCUMENT TO ANY OTHER PERSON OR ENTITY, IN WHOLE OR IN PART, IS STRICTLY PROHIBITED. RACAL INSTRUMENTS, INC. IS NOT RESPONSIBLE FOR ANY DAMAGE OR LOSS OF PROFITS, BUSINESS, OR REPUTATION, OR FOR ANY SPECIAL, INCIDENTAL, OR CONSEQUENTIAL DAMAGES, INCLUDING ATTORNEY'S FEES, ARISING FROM THE USE OF THIS DOCUMENT. THIS DOCUMENT IS THE PROPERTY OF RACAL INSTRUMENTS, INC. AND IS TO BE RETURNED TO RACAL INSTRUMENTS, INC. UPON REQUEST. RACAL INSTRUMENTS, INC. IS NOT RESPONSIBLE FOR ANY DAMAGE OR LOSS OF PROFITS, BUSINESS, OR REPUTATION, OR FOR ANY SPECIAL, INCIDENTAL, OR CONSEQUENTIAL DAMAGES, INCLUDING ATTORNEY'S FEES, ARISING FROM THE USE OF THIS DOCUMENT.

Racal Instruments, Inc.			
4 Goodyear St., Irvine, CA. 92718-2002			
DOCUMENT TITLE			
POB ASSY, 1260-54			
SIZE	CODE IDENT NO.	DOCUMENT NO.	REV.
D	21793	401908	J
SCALE	1/1	SHEET	1 OF 4

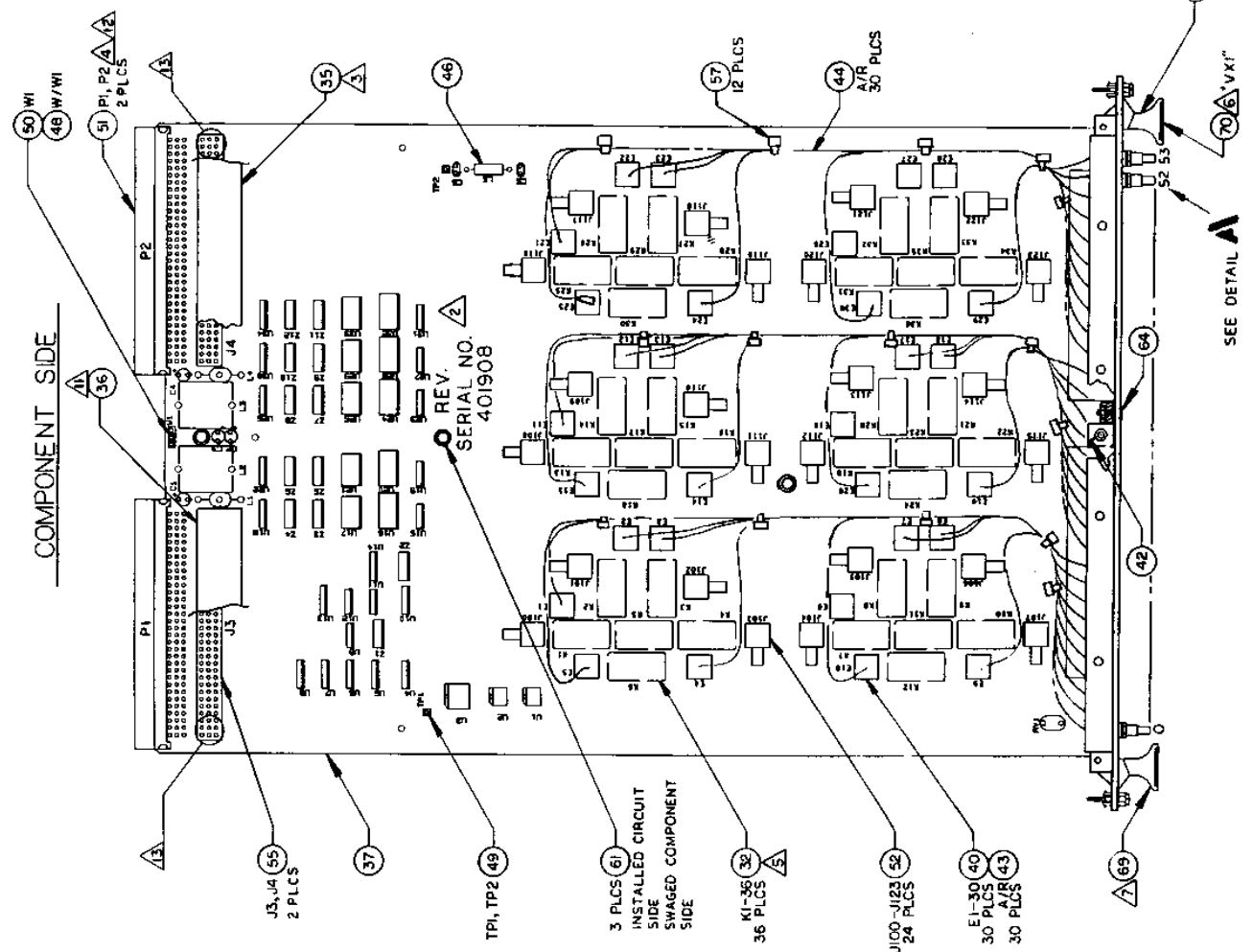

CIRCUIT SIDE

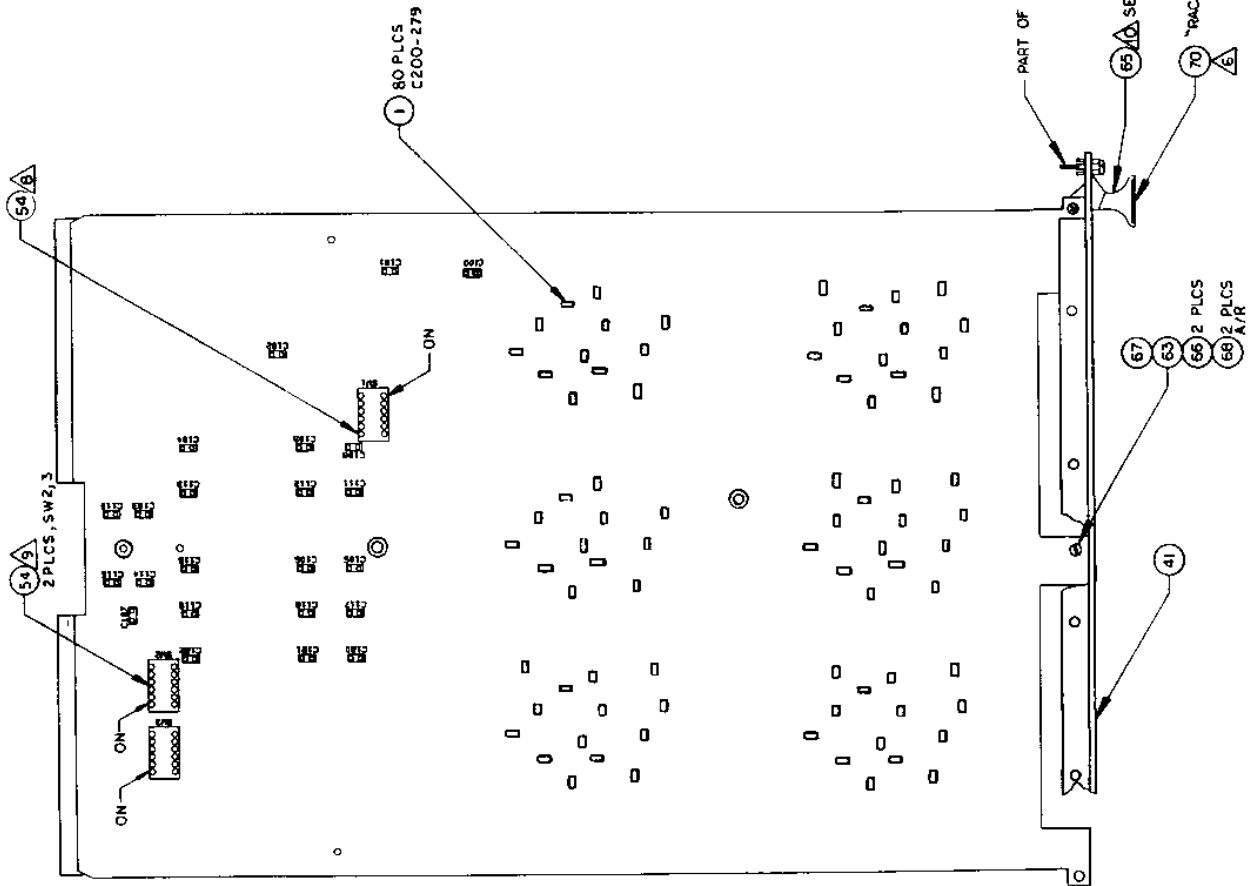

- 15 TORQUE NUT TO 80 INCH OZ.
- 14 TORQUE NUTS AGAINST EACH OTHER TO 100 INCH OZ. PRIOR TO INSTALLING CONNECTOR ON FRONT PANEL.
- 13 SOLDER TAILS ON CIRCUIT SIDE OF PCB FOR J3 AND J4 (ITEM 55) 3 ROWS (9 PINS) NEAREST EDGE OF PCB TO BE TRIMMED TO A MAXIMUM HEIGHT OF .045.
- 12 SOLDER TAILS ON CIRCUIT SIDE OF PCB FOR P1 & P2 (ITEM 51) TO BE TRIMMED TO A MAXIMUM HEIGHT OF .045.
- 11 INSTALL (ITEM 36) PCB INTO (ITEM 55) J3.
- 10 ITEM 62 CONSISTS OF 1 BOTTOM HANDLE, MOUNTING BLOCK AND ASSOCIATED PARTS.
- 9 ITEM 65 IS THE SAME (AS ITEM 62) BUT THE HANDLE IS FOR THE TOP.
- 8 SET ALL S2,S3 TO (ON) OR (CLOSED) OR (1) POSITION. DO NOT WAVE SOLDER.
- 7 SET S1 TO LOGICAL ADDRESS 1 PER TABLE 1. DO NOT WAVE SOLDER.
- 6 ITEM 69 CONSISTS OF MOUNTING HARDWARE FOR HANDLES, AND ASSOCIATED PARTS. DISCARD UNUSED HARDWARE SUPPLIED WITH ITEM 69.
- 5 INSTALL ITEM 70 (RACAL INST.VXI LABELS) RIGHT-READING WITH ITEM 41.
- 4 RELAYS (ITEM 32) TO BE INSTALLED .007MIN/.020MAX ABOVE PCB.
- 3 P1 & P2 MUST BE INSTALLED FLUSH AT RIGHT ANGLE TO PCB.
- 2 INSTALL (ITEM 35) PCB INTO (ITEM 56) J4.
- 1 INK STAMP SERIAL NUMBER AND CURRENT REVISION ON COMPONENT SIDE IN INDICATED AREA.

1. REFERENCE SCHEMATIC 431908.
NOTES, UNLESS OTHERWISE SPECIFIED

SIZE	CODE IDENT NO	DOCUMENT NO	REV
D	21793	401908	J
SCALE 1/1		SHEET	2 OF 4

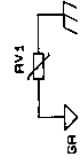
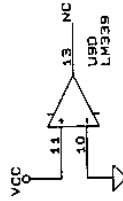
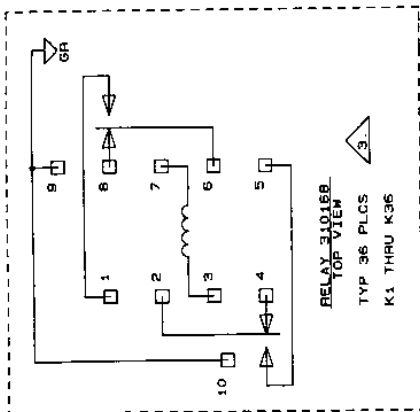

U17, 21, 25, 29, 33	2803	9
U16, 20, 24, 28, 32	74HCT273	20
U14	74HCT85	16
U13	74LS138	15
U11, 12, 15, 19, 23, 27, 31	74HCT164	14
U10, 18, 22, 26, 30, 34	74HCT166	15
U9	LM339	3
U7, 8	26LS32	16
U6	26LS31	16
U4, 5	74HCT253D	16
U3	231154 (22V10H)	28
U2	231153 (15R4)	20
U1	231152 (16L80)	20
REF. DES.	IC TYPE	IC PIN NO.
		+5V
		GND
		PIN NO.

212
W1
U34
TP2
SW3
RV1
P2
L5
K36
J123
E30
C279
HIGHEST REF. DES.

IC POWER AND GROUND CONNECTIONS

- 6. REFER TO SHEET 12 FOR CONNECTIONS.
- 5. REFERS TO LOGIC GROUND. GR REFERS TO SIGNAL GROUND.
- 4. C5 AND C6 ARE NOT INSTALLED.
- 3. RELAYS K1 THRU K36 ARE RACAL P/N 310168.
- 2. ALL RELAYS SHOWN IN DE-ENERGIZED POSITION.
- 1. RESISTOR NETWORKS ARE IN OHMS, ±2%.
- 1. CAPACITOR VALUES ARE IN MICROFARADS, 50V, ±/-20%

NOTES: UNLESS OTHERWISE SPECIFIED

Racal Instruments, Inc.
4 Goodyear St., Irvine, CA. 92718-2002

DOCUMENT TITLE
SCH, 1260-54

SIZE CODE IDENT NO. DOCUMENT NO. REV.
B 21793 431908 A

SCALE SHEET 1 OF 12

PROPRIETARY NOTICE

THIS DOCUMENT AND THE TECHNICAL DATA HEREIN CONTAINED THEREIN ARE PROPRIETARY TO RACAL INSTRUMENTS INC. AND SHALL NOT, WITHOUT THE EXPRESS WRITTEN PERMISSION OF RACAL INSTRUMENTS INC. BE USED, REPRODUCED, COPIED, OR DISCLOSED IN ANY MANNER TO ANY COMPETITIVE SOURCE OR USED FOR THE MANUFACTURE BY ANYONE OTHER THAN RACAL INSTRUMENTS INC. THE INFORMATION HEREIN HAS BEEN DEVELOPED AT PRIVATE EXPENSE AND MAY NOT BE USED FOR REPRODUCTION INTO TECHNICAL SPECIFICATIONS AND OTHER DOCUMENTS WHICH SPECIFY PROCUREMENT OF PRODUCTS FROM RACAL INSTRUMENTS INC.

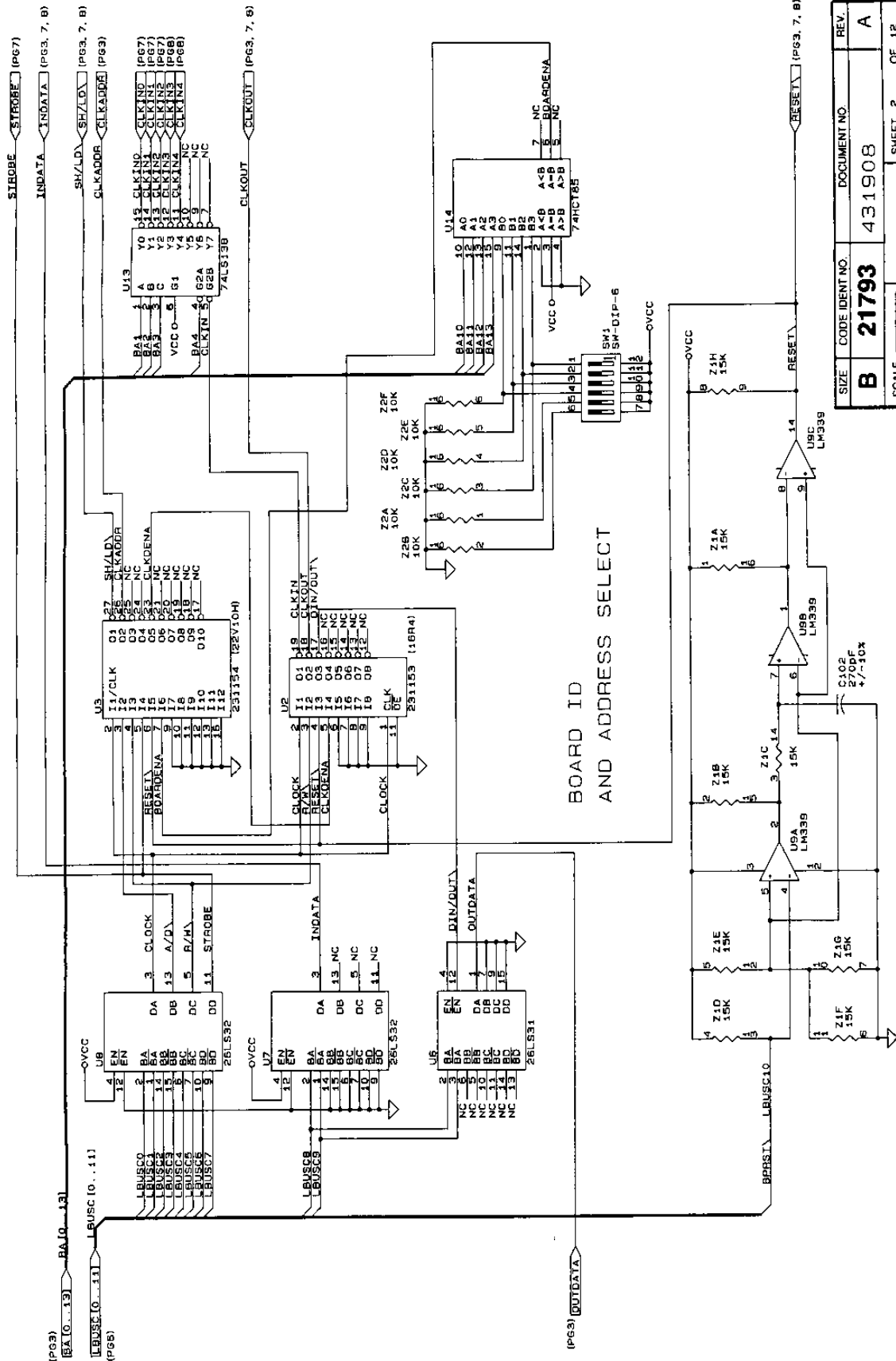

SIZE	CODE IDENT NO.	DOCUMENT NO.	REV.
B	21793	431908	A
SCALE	SHEET 2 OF 12		

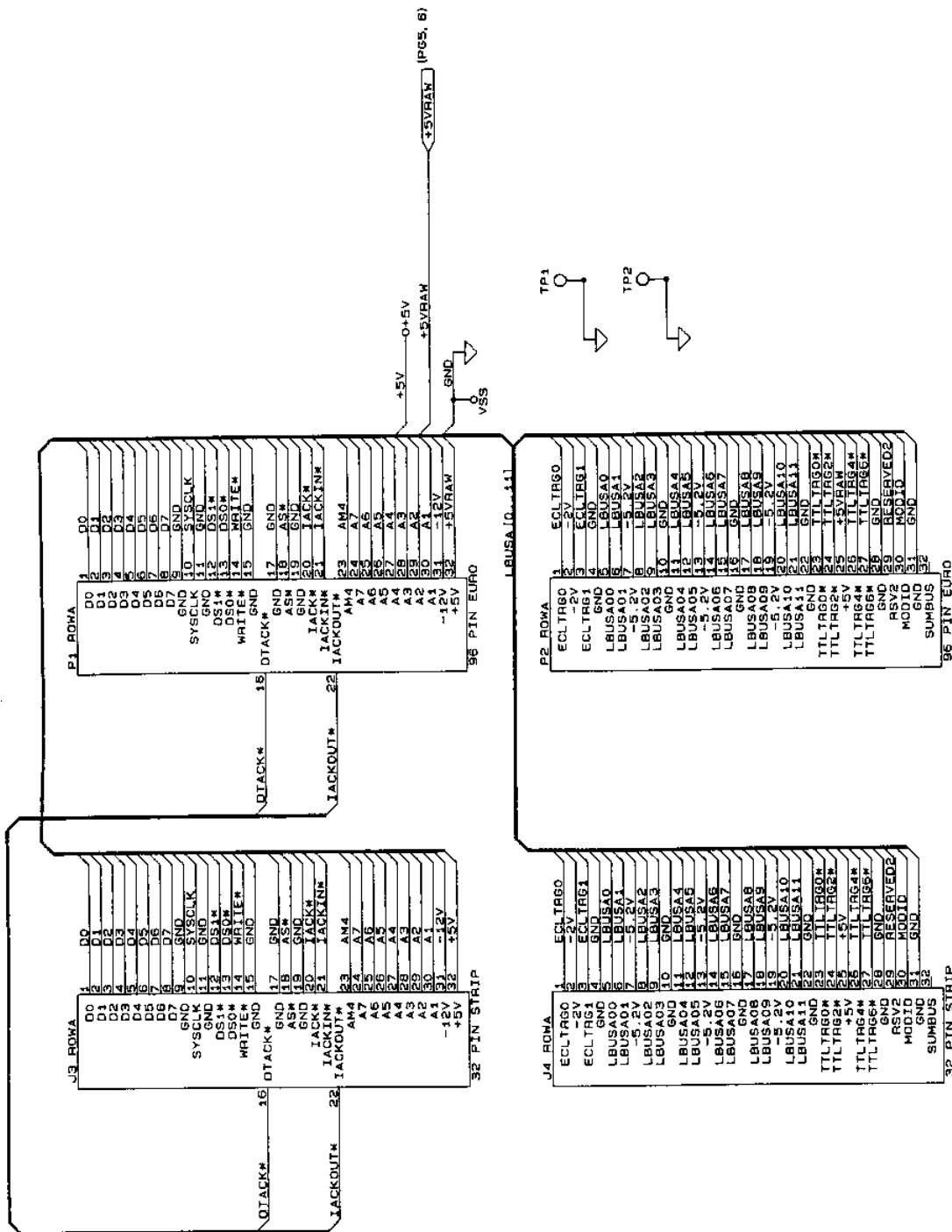

SIZE	CODE IDENT NO.	DOCUMENT NO.	REV
B	21793	431908	A
SCALE		SHEET 4	OF 12

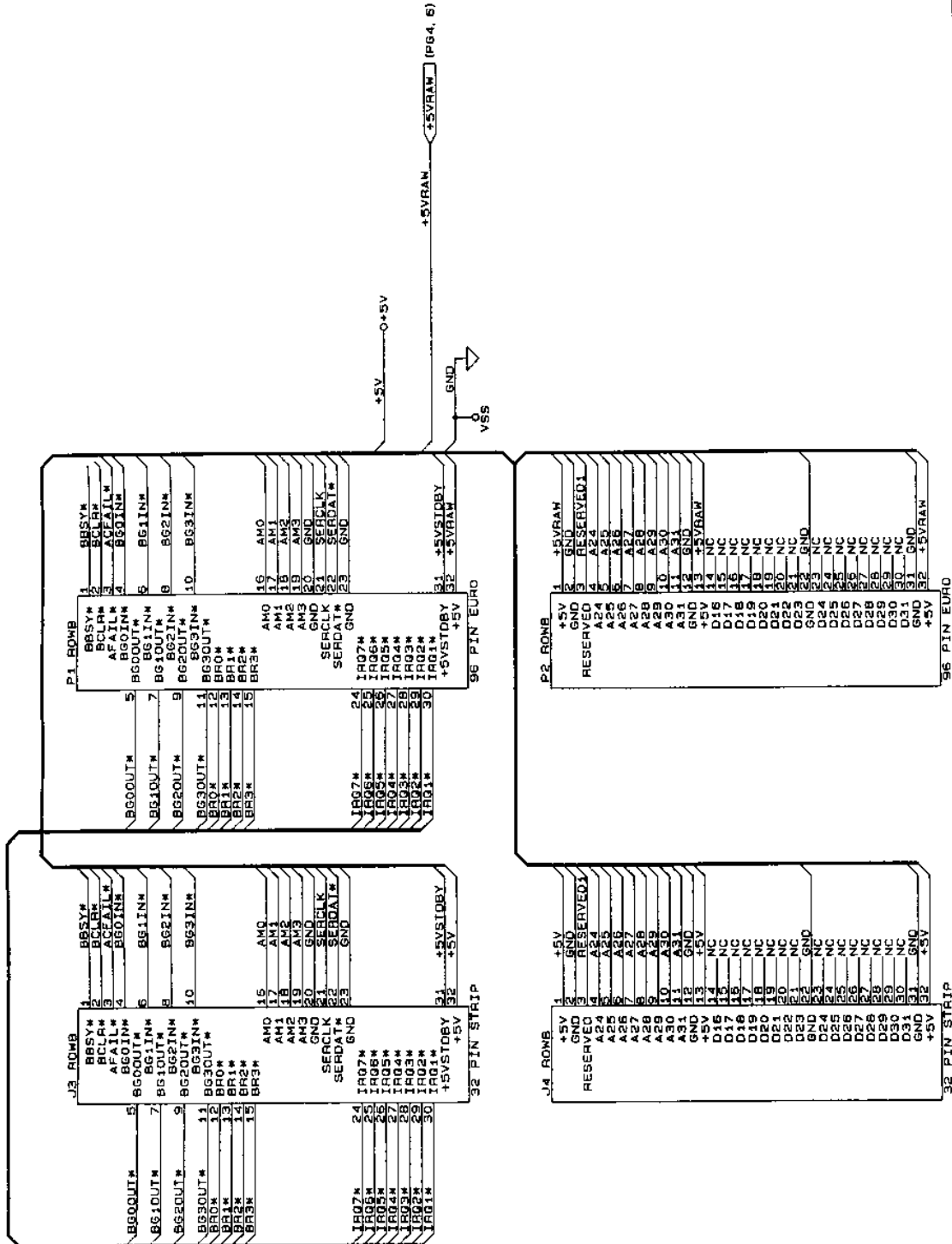

Drawings 4-10

SIZE	CODE IDENT NO.	DOCUMENT NO.	REV.
B	21793	431908	A
SCALE		SHEET 5	OF 12

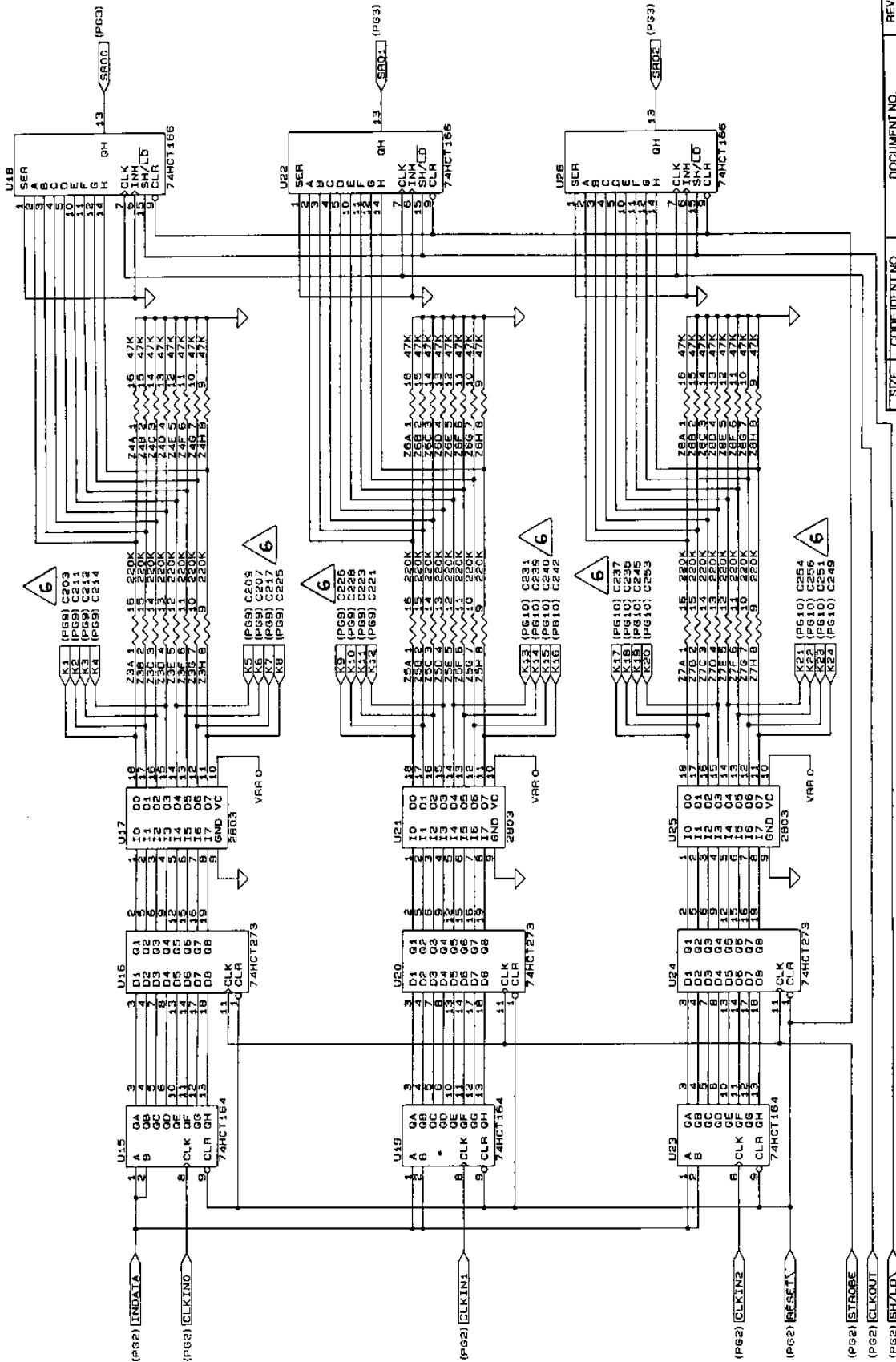

SIZE	CODE IDENT NO.	DOCUMENT NO.	REV.
B	21793	431908	A
SCALE		SHEET 7	OF 12

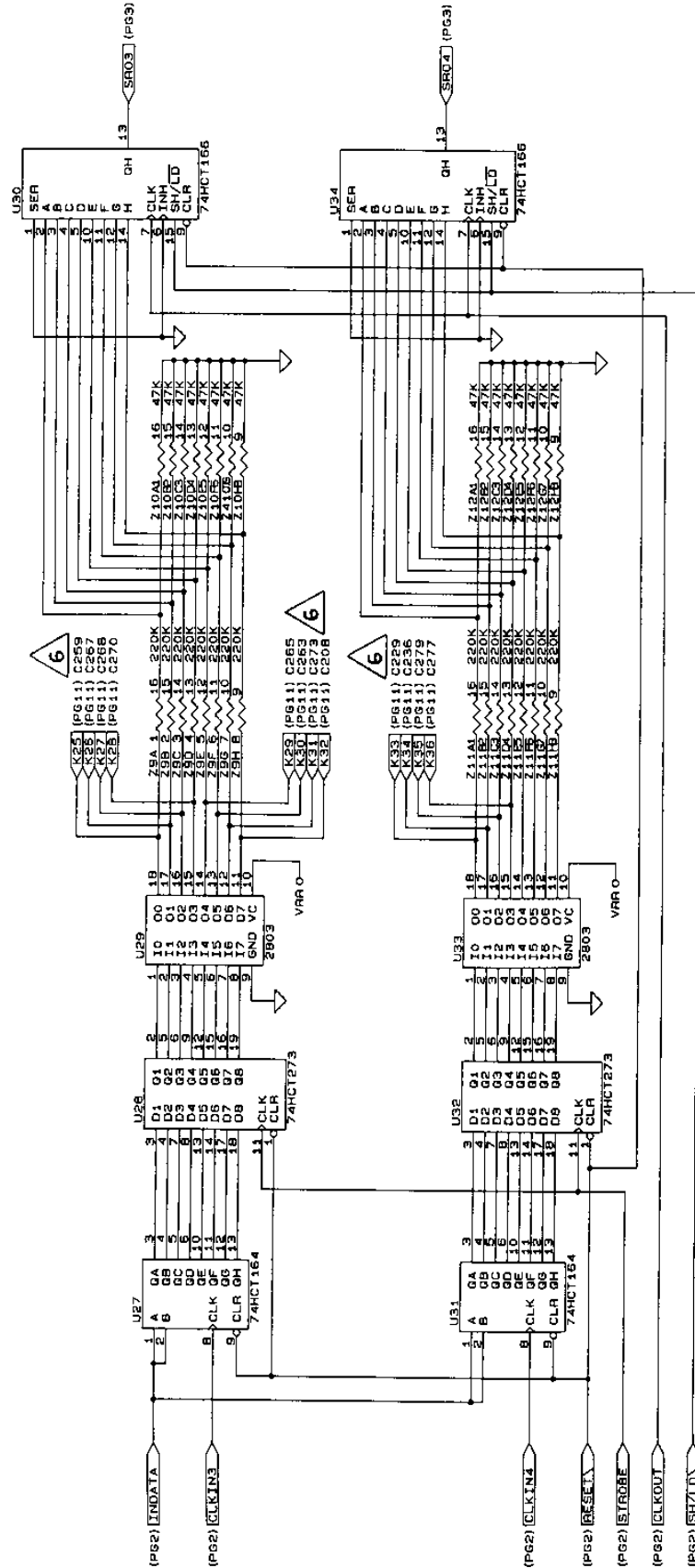

SIZE	CODE IDENT NO.	DOCUMENT NO.	REV.
B	21793	431908	A
SCALE		SHEET B	OF 12

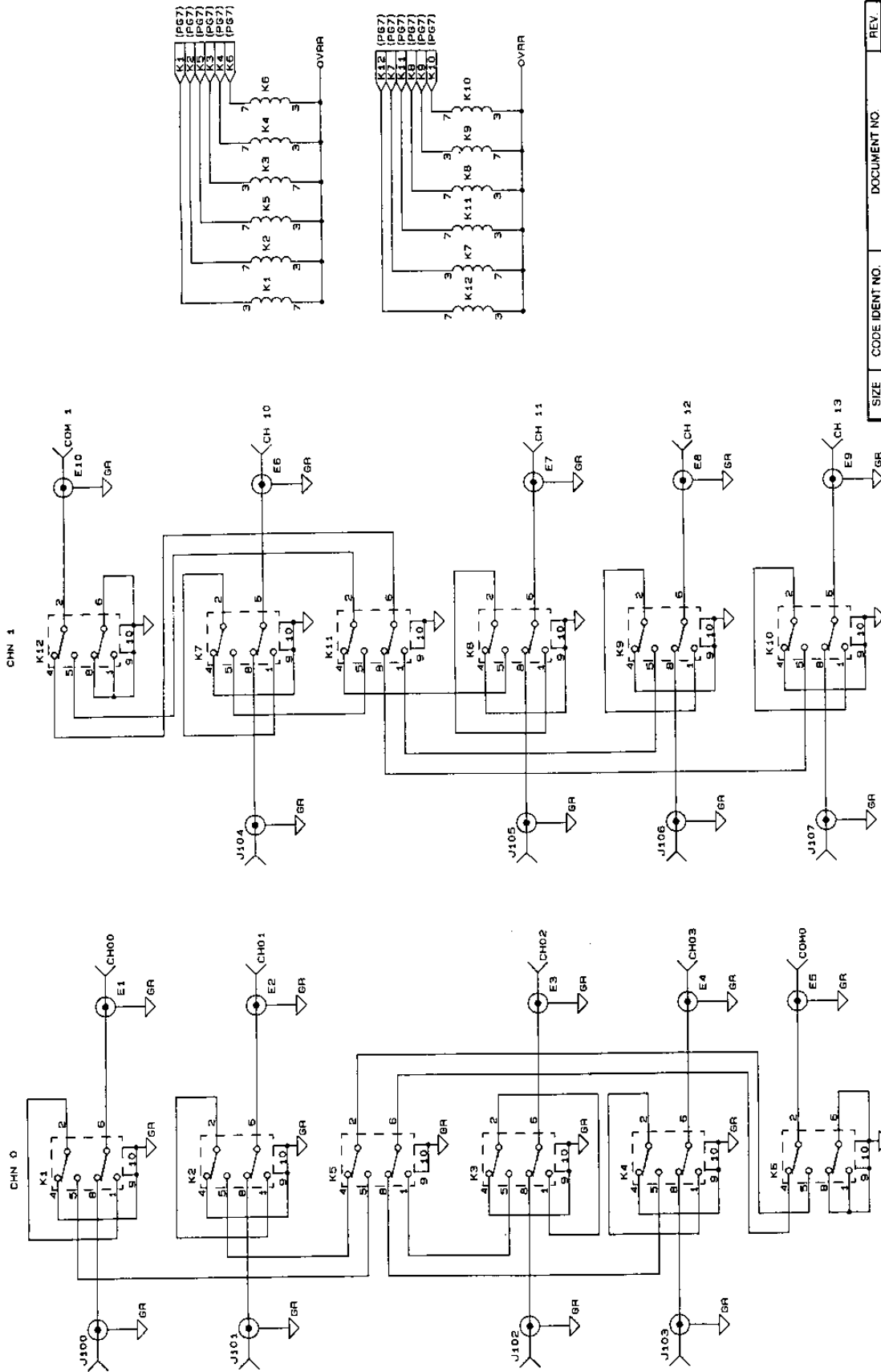

SIZE	CODE IDENT NO.	DOCUMENT NO.	REV.
B	21793	431908	A
SCALE		SHEET 9	OF 12

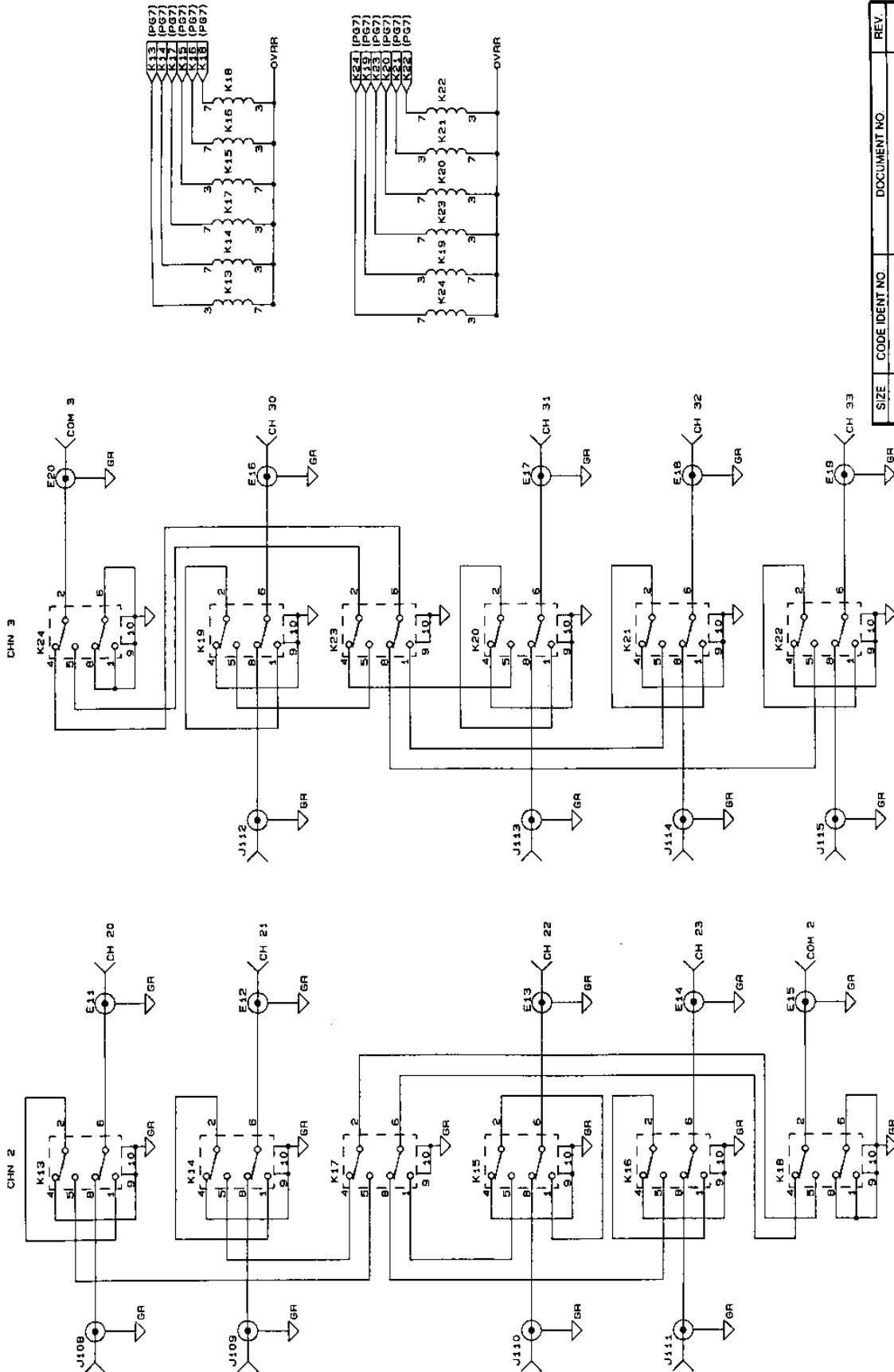

SIZE	CODE IDENT NO.	DOCUMENT NO.	REV.
B	21793	431908	A
SCALE		SHEET 10	OF 12

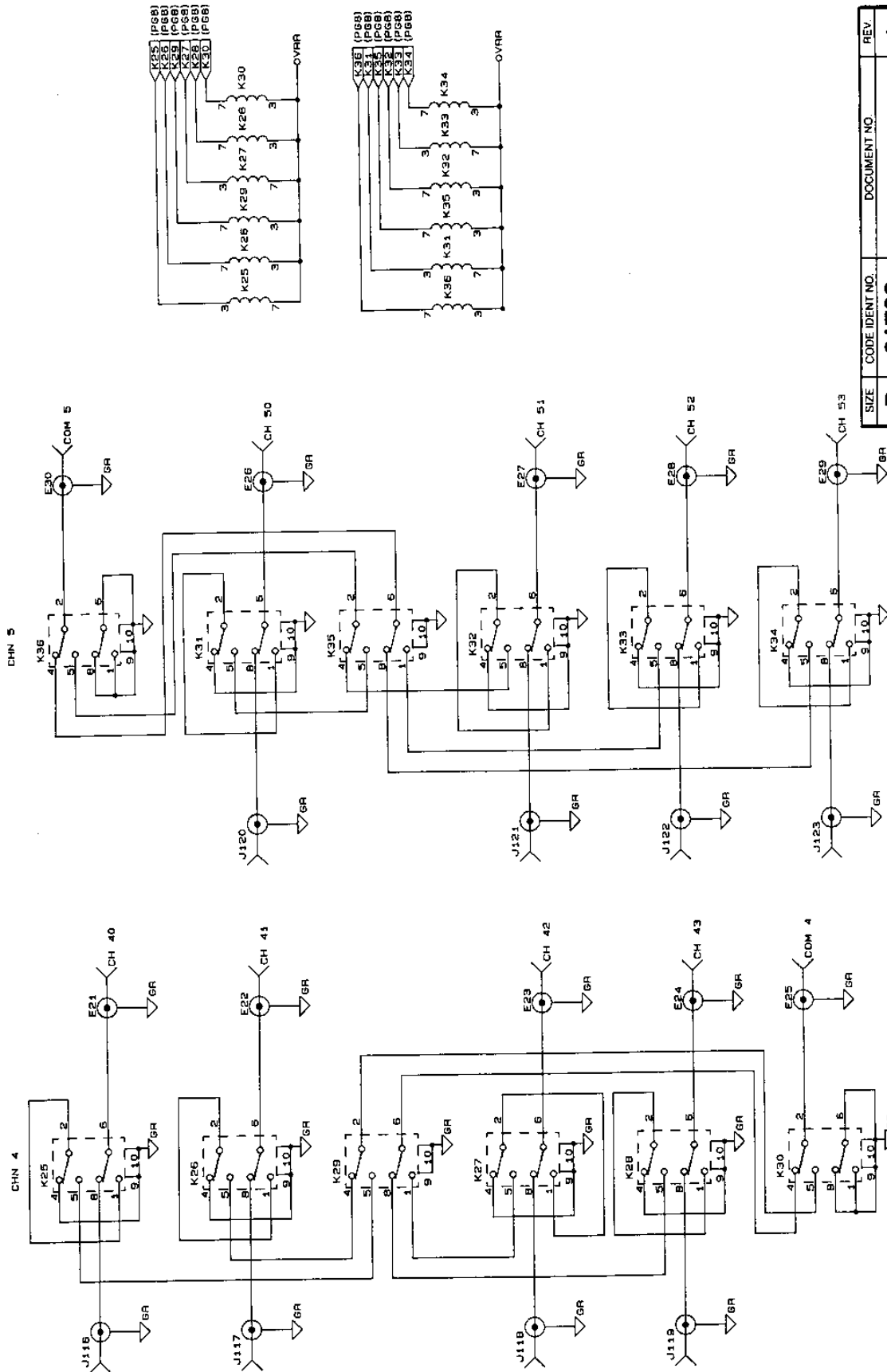

SIZE	CODE IDENT NO.	DOCUMENT NO.	REV.
B	21793	431908	A
SCALE		SHEET 11	OF 12

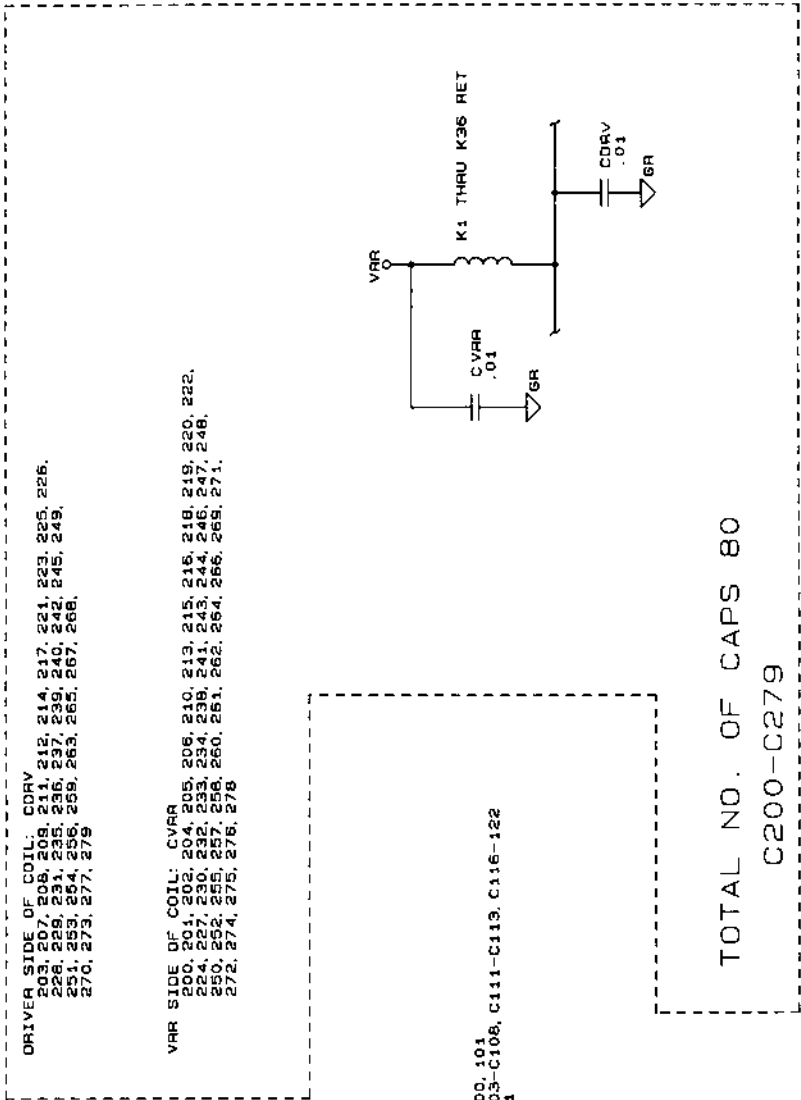

SIZE	CODE IDENT NO.	DOCUMENT NO.	REV.
B	21793	431908	A
SCALE		SHEET 12	OF 12

This page was left intentionally blank.

Chapter 5

PARTS LIST

404768, Final Assembly, 1260-54	5-3
401908, PCB Assy, 1260-54	5-4
407101, Shipping Kit, 1260-54	5-6
List of Suppliers.....	5-7

This page was left intentionally blank.

User Manual 1260-54

404768 - FINAL ASSY, 1260-54

REF DESIG	RACAL P/N	INST DESCRIPTION	FSC	MANUFACTURER'S P/N
{1}1	401908	PCB ASSY., 1260-54	21793	401908
{3}1	407101	SHIPPING KIT, 1260-54	21793	407101
{5}1	921059	LABEL, CAUTION, STATIC	21793	921059
{9}1	455781	PANEL, REAR, SINGLE	21793	455781
{11}1	455784-001	PANEL, VXI TOP	21793	455784-001
{13}1	455784-002	PANEL, VXI BOTTOM	21793	455784-002
{15}1	455780	PANEL, LEFT, 1260-54	21793	455780
{17}1	455780-001	PANEL, RIGHT, 1260-54	21793	455780-001
{19}8	616480	SCREW, PFH, 4-40 X .375	-	-
{21}33	615539	SCREW, PFH, 4-40X. 125	-	-
{23}1	921309	LABEL, VXI SWITCH IDENTIFICATION	21793	921309

401908 - PCB ASSY, 1260-54

REF	RACAL INST	DESCRIPTION	FSC	MANUFACTURER'S P/N
DESIG	P/N			
C1-C4	1110126	CAP, TANTA, 6.8UF, 35V, 20 PERCENT	105397	T355F685M035A5
C100	R-21-1801	CAP, CHIP, 10 NF	195275	VJ1206Y103MF
C102	1130177	CAPACITOR, CHIP, SMD, 270PF	195275	VJ1206A271KXAMT
C102	R-21-1801	CAP, CHIP, 10 NF	195275	VJ1206Y103MF
C103-C122	R-21-1801	CAP, CHIP, 10 NF	195275	VJ1206Y103MF
C200-C279	R-21-1801	CAP, CHIP, 10 NF	195275	VJ1206Y103MF
J3	1601925	CONNECTOR, PCB, RECEPT, 3 ROW, 96P	152072	1618008
J4	1601925	CONNECTOR, PCB, RECEPT, 3 ROW, 96P	152072	1618008
J100-J123	1601787-001	CONNECTOR, COAXIAL, RECEPTACLE	19505	12010-1511-000
K1-K36	1310168	RELAY, RF, 2 FORM C	101526	13SAV2590A2
L1	1100164	CAP, FEED-THRU, 800PF, 50V	100779	1842448-2
L1	1600245	JUMPER, INSULATED	152210	1L-2007-1
L2	1310193	CHOKER, SHIELDED, 5UH	191637	1IH-5-5-10
L3	1310193	CHOKER, SHIELDED, 5UH	191637	1IH-5-5-10
L4	1100164	CAP, FEED-THRU, 800PF, 50V	100779	1842448-2
P1	1601675-001	CONNECTOR, EUROCARD, 96 PIN MOD.	121793	1601675-001
P2	1601675-001	CONNECTOR, EUROCARD, 96 PIN MOD.	121793	1601675-001
RV1	1220102	VARISTOR, 56V, 1.7W	103508	1V562A2
SW1-SW3	1601969	SWITCH, DIP 6 POS, LOW PROFILE	165832	1K406S
TP1	1601197	POST, TEST, .025 SQ	100779	16-87022-6
TP2	1601197	POST, TEST, .025 SQ	100779	16-87022-6
U1	1231152	IC, PROGRAMMED PLA	121793	1231152
U2	1231153	IC, PROGRAMMED PLA	121793	1231153
U3	1231154	IC, PROGRAMMED PLA	121793	1231154
U4	1231147	IC, MULTIPLEXER	104713	174HC253D
U5	1231147	IC, MULTIPLEXER	104713	174HC253D
U6	1231125	IC, DIGITAL, LINE DRIVER	127014	1DS26LS31MN
U7	1231096	IC, QUAD DIFF RECEIVER	101295	1AM26LS32ACD
U8	1231096	IC, QUAD DIFF RECEIVER	101295	1AM26LS32ACD
U9	1231093	IC, QUAD COMPARATOR	104713	1LM339D
U10	1231120	IC, 8-BIT, PARALLEL/SERIAL OUT S.R.	118324	174HCT166D
U11	1231131	IC, DIGITAL, SHIFT REGISTER	118324	1PC74HCT164D
U12	1231131	IC, DIGITAL, SHIFT REGISTER	118324	1PC74HCT164D
U13	1231094	IC, DEMUX DECODER	118324	1N74LS138D
U14	1231135	IC, DIGITAL, 4-BIT COMPARATOR	118324	1PC74HCT85D
U15	1231131	IC, DIGITAL, SHIFT REGISTER	118324	1PC74HCT164D
U16	1231130	IC, DIGITAL, FLIP FLOP	118324	1PC74HC273
U17	1231098	IC, SOIC TRANSISTOR	156289	1ULN-2803LW
U18	1231120	IC, 8-BIT, PARALLEL/SERIAL OUT S.R.	118324	174HCT166D
U19	1231131	IC, DIGITAL, SHIFT REGISTER	118324	1PC74HCT164D
U20	1231130	IC, DIGITAL, FLIP FLOP	118324	1PC74HC273
U21	1231098	IC, SOIC TRANSISTOR	156289	1ULN-2803LW
U22	1231120	IC, 8-BIT, PARALLEL/SERIAL OUT S.R.	118324	174HCT166D
U23	1231131	IC, DIGITAL, SHIFT REGISTER	118324	1PC74HCT164D
U24	1231130	IC, DIGITAL, FLIP FLOP	118324	1PC74HC273
U25	1231098	IC, SOIC TRANSISTOR	156289	1ULN-2803LW
U26	1231120	IC, 8-BIT, PARALLEL/SERIAL OUT S.R.	118324	174HCT166D
U27	1231131	IC, DIGITAL, SHIFT REGISTER	118324	1PC74HCT164D
U28	1231130	IC, DIGITAL, FLIP FLOP	118324	1PC74HC273
U29	1231098	IC, SOIC TRANSISTOR	156289	1ULN-2803LW
U30	1231120	IC, 8-BIT, PARALLEL/SERIAL OUT S.R.	118324	174HCT166D
U31	1231131	IC, DIGITAL, SHIFT REGISTER	118324	1PC74HCT164D
U32	1231130	IC, DIGITAL, FLIP FLOP	118324	1PC74HC273
U33	1231098	IC, SOIC TRANSISTOR	156289	1ULN-2803LW
U34	1231120	IC, 8-BIT, PARALLEL/SERIAL OUT S.R.	118324	174HCT166D
W1	1601208-016	CONNECTOR, PCB, PLUG, 3-PIN	152072	1CA-S03-23B-43

User Manual 1260-54

401908 PCB ASSY., 1260-54

REF DESIG	RACAL-INST P/N	DESCRIPTION	FSC	MANUFACTURER'S P/N
Z1	080114	RES NETWORK, 16P8R, 15K	73138	628-AL-153J
Z2	080120	RES NETWORK, 10K	11236	767-161R10K
Z3	080119	RES NETWORK, 220K	91637	SOMC-1603-224K
Z4	080117	RES NETWORK, 16P8R, 47K	73138	628-AL-473J
Z5	080119	RES NETWORK, 220K	91637	SOMC-1603-224K
Z6	080117	RES NETWORK, 16P8R, 47K	73138	628-AL-473J
Z7	080119	RES NETWORK, 220K	91637	SOMC-1603-224K
Z8	080117	RES NETWORK, 16P8R, 47K	73138	628-AL-473J
Z9	080119	RES NETWORK, 220K	91637	SOMC-1603-224K
Z10	080117	RES NETWORK, 16P8R, 47K	73138	628-AL-473J
Z11	080119	RES NETWORK, 220K	91637	SOMC-1603-224K
Z12	080117	RES NETWORK, 16P8R, 47K	73138	628-AL-473J
{35}1	401951	PCB ASSY., LBUS JUMPER	21793	401951
{36}1	401951-003	PCB ASSY., P3 JUMPER	21793	401951-003
{37}1	411908	PCB 1260-54 (UNLOADED)	21793	411908
{41}1	455687-002	PANEL, FRONT, SMC CONNECTOR	21793	455687-002
{42}1	601984	BRACKET, SUPPORT, PCB	67349	VMEB2000
{43}A/R	500009	TUBING, SHRINK, .12 ID, BLK	29005	RNF-100-1-1/8
{44}A/R	500254	CABLE, COAXIAL, 50 OHM	92194	9178B
{48}1	601195	PLUG, JUMPER, 0.1 CTR, LOW PROFILE	00779	530153-2
{56}30	601944	CONNECTOR, RECEPTACLE, PANEL MOUNT SMC	98291	50-010-3196
{57}12	610777	CABLE TIE	16956	08-432
{59}30	611348	WASHER, #8, FLAT PHENOLIC INSUL.	86928	5620-10-31
{60}30	611349	WASHER, SHOULDER, PHENOLIC INSUL.	55566	5777-PH-045-208
{61}3	611258-001	STANDOFF, SWAGE 4-40 X .170	06540	8091-11B-B-440-28
{62}1	611264	HANDLE, EXTRACTOR, BOTTOM	62559	20817-327
{63}1	615016	SCREW, PFH, 2-56 X .375	-	-
{64}1	615514	SCREW, PFH, 2-56 X .312	-	-
{65}1	611265	HANDLE, EXTRACTOR, TOP	62559	20817-328
{66}2	617002	NUT, HEX, 2-56	-	-
{67}1	617101	WASHER, FLAT, LIGHT SERIES, #2	-	-
{68}A/R	920962	LOCTITE, 242, MED STR.	05972	272
{69}.5	611266	MOUNTING HARDWARE, HANDLE	62559	21100-745
{70}1	921148-001	LABEL SET, VXI	21793	921148-001
{71}2	616405	SCREW, PFH, M2.5-.45 X 12	-	-

407101 - SHIPPING KIT, 1260-54

REF	RACAL INST	DESCRIPTION	FSC	MANUFACTURER'S P/N
DESIG	P/N			
{1}2	455540	KEY, LOCKOUT, TTL, A/C	21793	455540
{2}2	455541	KEY, LOCKOUT, TTL, C	21793	455541
{3}2	455542	KEY, LOCKOUT, TTL, A	21793	455542
{5}3	1615013	SCREW, PPF, 2-56 X .188	-	-
{10}1	980673-009	MANUAL, 1260-54 MODULE	21793	980673-009

List of Suppliers

FSC	SUPPLIER	FSC	SUPPLIERS
00779	AMP, INC. HARRISBURG, PA	65832	AMERICAN RESEARCH & ENGINEERING ELGIN, IL
01295	TEXAS INSTRUMENTS, INC. DALLAS, TX	67349	PHILLIPS COMPONENTS INC. LAGUNA HILLS, CA
01526	GENICOM CORP. WAYNESBORO, VA	73138	BECKMAN INSTRUMENTS FULLERTON, CA
03508	GENERAL ELECTRIC CO. (SEMICONDUCTOR PRODUCTS) AUBURN, NY	86928	SEASTROM MFG. CO. GLENDALE, CA
04713	MOTOROLA, INC. (SEMICONDUCTOR PRODUCTS DIV.) PHOENIX, AZ	91637	DALE ELECTRONICS, INC. COLUMBUS, NE
05397	UNION CARBIDE CORP. (MATERIALS SYSTEMS DIV.) CLEVELAND, OH	92194	ALPHA WIRE ELIZABETH, NJ
05972	LOCTITE CORP. HARTFORD, CT	95275	VITRAMON, INC. BRIDGEPORT, CT
06540	AMATOM ELECTRONIC HARDWARE NEW ROCHELLE, NY	98291	SEAELECTRO CORP. MAMARONECK, NY
11236	CTS OF BERNE, INC. BERNE, IN		
16956	DENNISON MFG. CO. FRAMINGTON, MA		
18324	SIGNETICS, INC. SUNNYVALE, CA		
19505	APPLIED ENGINEERING PRODUCTS NEW HAVEN, CT		
21793	RACAL INSTRUMENTS INC. IRVINE, CA		
27014	NATIONAL SEMI-CONDUCTOR CORP. SANTA CLARA, CA		
29005	STORM PRODUCTS CO. LOS ANGELES, CA		
52072	CIRCUIT ASSY. CORP. COSTA MESA, CA		
52210	GETTING ENGRG. & MFG. CO. SPRING MILLS, PA		
55566	RAF ELECTRONIC HARDWARE INC. SEYMOUR, CT		
56289	SPAGUE ELECTRIC CO. N. ADAMS, MA		
62559	SCHROFF, INC. WARWICK, RI		

This page was left intentionally blank.

Chapter 6

OPTIONAL HARNESS ASSEMBLIES

The following harness assemblies are used to connect Racal Instruments Model 1260-54 to Freedom Series Test Receiver Interfaces.

Each harness documentation consists of an assembly drawing, parts list, and wire list.

407291, Virginia Panel, Inc. Series VP90 Interface Harness	6-3
407292, TTI Testron, Inc. Interface Harness	6-8
(TTI Receiver must be above chassis)	

For more information on Racal Instruments complete line of Test Receiver Interface solutions, contact your Sales Representative.

This page was left intentionally blank.

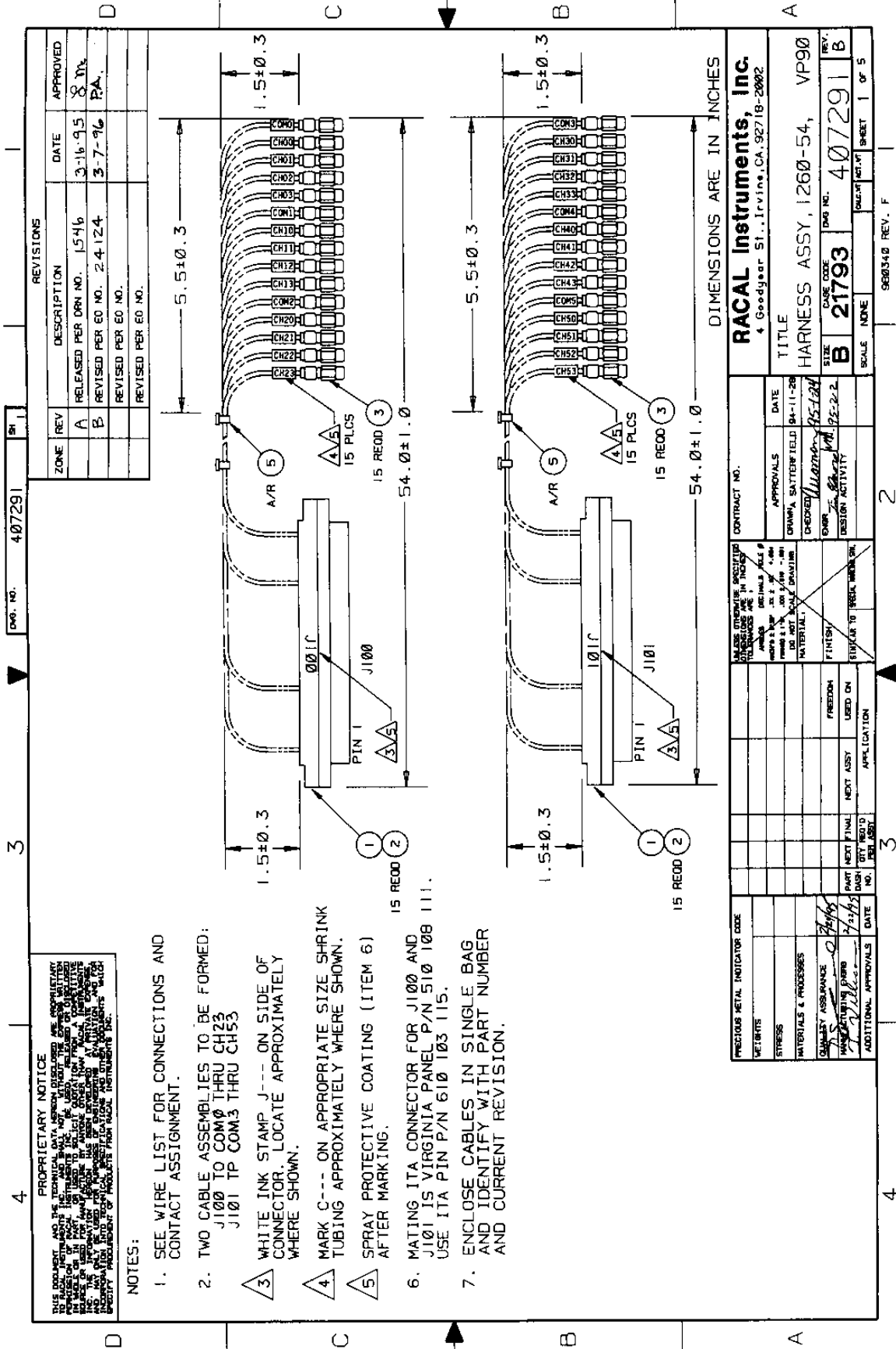

REVISIONS				
ZONE	REV	DESCRIPTION	DATE	APPROVED
A	1	RELEASED PER DRN NO. 15416	3-16-95	[Signature]
B	2	REVISED PER ED NO. 24124	3-7-96	PA.
		REVISED PER ED NO.		
		REVISED PER ED NO.		

Dwg. No. 407291		SH 1	
3		4	
PRECISOR METAL INDICATOR CODE		CONTRACT NO.	
WEIGHTS		APPROVALS	
STRESS		DATE	
MATERIALS & PROCESSES		DRAWING STATE FIELD 94-11-28	
QUALITY ASSURANCE		CHECKED <i>Luomo</i> 95124	
TOLERANCES UNLESS OTHERWISE SPECIFIED ARE IN INCHES		DRAWN <i>W. J. ...</i> 95-2-2	
FINISH		DESIGN ACTIVITY	
PART NEXT FINAL		SCALE NONE	
DUSH QTY REQ'D		Dwg No. 407291	
NO. DEL. SET		REV. B	
APPLICATION		SHEET 1 OF 5	
4		2	
3		1	

PROPRIETARY NOTICE
 THIS DOCUMENT AND THE TECHNICAL DATA HEREON DISCLOSED ARE PROPRIETARY PROPERTY OF RACAL INSTRUMENTS, INC. THE USER OF THIS DOCUMENT OR INFORMATION CONTAINED HEREIN IS TO BE LIMITED TO THE SPECIFIC ORDER FROM WHICH THIS DOCUMENT WAS OBTAINED. THE INFORMATION CONTAINED HEREIN IS NOT TO BE REPRODUCED, COPIED, OR TRANSMITTED IN ANY FORM OR BY ANY MEANS, ELECTRONIC OR MECHANICAL, INCLUDING PHOTOCOPYING, RECORDING, OR BY ANY INFORMATION STORAGE AND RETRIEVAL SYSTEM, WITHOUT THE WRITTEN PERMISSION OF RACAL INSTRUMENTS, INC.

NOTES:

- SEE WIRE LIST FOR CONNECTIONS AND CONTACT ASSIGNMENT.
- TWO CABLE ASSEMBLIES TO BE FORMED:
 J100 TO COM0 THRU CH23
 J101 TP COM3 THRU CH53
- WHITE INK STAMP J--- ON SIDE OF CONNECTOR. LOCATE APPROXIMATELY WHERE SHOWN.
- MARK C--- ON APPROPRIATE SIZE SHRINK TUBING APPROXIMATELY WHERE SHOWN.
- SPRAY PROTECTIVE COATING (ITEM 6) AFTER MARKING.
- MATING ITA CONNECTOR FOR J100 AND J101 IS VIRGINIA PANEL P/N 510 108 111. USE ITA PIN P/N 610 103 115.
- ENCLOSE CABLES IN SINGLE BAG AND IDENTIFY WITH PART NUMBER AND CURRENT REVISION.

DIMENSIONS ARE IN INCHES

RACAL Instruments, Inc.
 4 Goodyear St., Irvine, CA. 92718-2002

TITLE
 HARNESS ASSY, 1260-54, VP90

SIZE **B** CASE CODE **21793** Dwg No. **407291** REV. **B**

SCALE NONE SHEET 1 OF 5

950340 REV. F

ENGINEERING WIRE LIST

WIRE	FROM	TO	TYPE	PART #	WIRE LEN	REFERENCE
	BLK AA (J100)	Uxx-SLOT yy (E1-E15)	CABLE	407291		SYSTEM WIRE LIST
	BLK AA (J101)	Uxx-SLOT yy (E16-E30)	CABLE	407291		
<p>This system wirelist serves as a template for incorporating this harness assembly into the overall system wirelist. It does not in any way affect the fabrication of this harness assembly.</p>						
<div style="display: flex; justify-content: space-around;"> <div style="width: 20%; height: 100px; border: 1px solid black;"></div> <div style="width: 20%; height: 100px; border: 1px solid black;"></div> <div style="width: 20%; height: 100px; border: 1px solid black;"></div> <div style="width: 20%; height: 100px; border: 1px solid black;"></div> <div style="width: 20%; height: 100px; border: 1px solid black;"></div> <div style="width: 20%; height: 100px; border: 1px solid black;"></div> </div>						
RACAL Instruments, Inc., 4 Goodyear St., Irvine, CA 92718						
DOCUMENT TITLE			SIZE	CODE NO.	DOCUMENT NO.	REV
HARNESS ASSEMBLY, 1260-54C, VP90			A	21793	407291	B
			DRN	SHEET 3 of 5		

DOC. NO. 407291

ENGINEERING WIRE LIST

WIRE	FROM	TO	TYPE	PART #	WIRE LEN	REFERENCE
1	J100-1 (602201-008)	E1 (600483)	COAX	602201-807	54"	CHANNEL 00
2	J100-2 (602201-008)	E2 (600483)	COAX	602201-807	54"	CHANNEL 01
3	J100-3 (602201-008)	E3 (600483)	COAX	602201-807	54"	CHANNEL 02
4	J100-4 (602201-008)	E4 (600483)	COAX	602201-807	54"	CHANNEL 03
5	J100-5 (602201-008)	E5 (600483)	COAX	602201-807	54"	COM 0
6	J100-6 (602201-008)	E6 (600483)	COAX	602201-807	54"	CHANNEL 10
7	J100-7 (602201-008)	E7 (600483)	COAX	602201-807	54"	CHANNEL 11
8	J100-8 (602201-008)	E8 (600483)	COAX	602201-807	54"	CHANNEL 12
9	J100-9 (602201-008)	E9 (600483)	COAX	602201-807	54"	CHANNEL 13
10	J100-10 (602201-008)	E10 (600483)	COAX	602201-807	54"	COM 1
11	J100-11 (602201-008)	E11 (600483)	COAX	602201-807	54"	CHANNEL 20
12	J100-12 (602201-008)	E12 (600483)	COAX	602201-807	54"	CHANNEL 21
13	J100-13 (602201-008)	E13 (600483)	COAX	602201-807	54"	CHANNEL 22
14	J100-14 (602201-008)	E14 (600483)	COAX	602201-807	54"	CHANNEL 23
15	J100-15 (602201-008)	E15 (600483)	COAX	602201-807	54"	COM 2
16	J100-16 NO CONNECT					
17	J100-17 NO CONNECT					
18	J100-18 NO CONNECT					
19	J100-19 NO CONNECT					
20	J101-1 (602201-008)	E16 (600483)	COAX	602201-807	54"	CHANNEL 30
21	J101-2 (602201-008)	E17 (600483)	COAX	602201-807	54"	CHANNEL 31
22	J101-3 (602201-008)	E18 (600483)	COAX	602201-807	54"	CHANNEL 32
23	J101-4 (602201-008)	E19 (600483)	COAX	602201-807	54"	CHANNEL 33
24	J101-5 (602201-008)	E20 (600483)	COAX	602201-807	54"	COM 3
25	J101-6 (602201-008)	E21 (600483)	COAX	602201-807	54"	CHANNEL 40

DOC NO. | 407291

RACAL Instruments, Inc., 4 Goodyear St., Irvine, CA 92718

DOCUMENT TITLE	SIZE	CODE NO.	DOCUMENT NO.	REV
HARNESS ASSEMBLY, 1260-54C, VP90	A	21793	407291	A
	DRN		SHEET 4 of 5	

ENGINEERING WIRE LIST

WIRE	FROM	TO	TYPE	PART #	WIRE LEN	REFERENCE
26	J101-7 (602201-008)	E22 (600483)	COAX	602201- 807	54"	CHANNEL 41
27	J101-8 (602201-008)	E23 (600483)	COAX	602201- 807	54"	CHANNEL 42
28	J101-9 (602201-008)	E24 (600483)	COAX	602201- 807	54"	CHANNEL 43
29	J101-10 (602201-008)	E25 (600483)	COAX	602201- 807	54"	COM 4
30	J101-11 (602201-008)	E26 (600483)	COAX	602201- 807	54"	CHANNEL 50
31	J101-12 (602201-008)	E27 (600483)	COAX	602201- 807	54"	CHANNEL 51
32	J101-13 (602201-008)	E28 (600483)	COAX	602201- 807	54"	CHANNEL 52
33	J101-14 (602201-008)	E29 (600483)	COAX	602201- 807	54"	CHANNEL 53
34	J101-15 (602201-008)	E30 (600483)	COAX	602201- 807	54"	COM 5
35	J101-16 NO CONNECT					
36	J101-17 NO CONNECT					
37	J101-18 NO CONNECT					
38	J101-19 NO CONNECT					

DOC. NO. 407291

RACAL Instruments, Inc., 4 Goodyear St., Irvine, CA 92718			
DOCUMENT TITLE	SIZE	CODE NO.	DOCUMENT NO.
HARNESS ASSEMBLY, 1260-54C, VP90	A	21793	407291
	DRN		SHEET 5 of 5
			REV B.

ENGINEERING WIRE LIST

WIRE	FROM	TO	TYPE	PART #	WIRE LEN	REFERENCE
	BLK AAx PN 01 (J100)	Uxx-SLOT yy (CH00)	CABLE	407292		SYSTEM WIRE LIST
	BLK AAx PN 02 (J101)	Uxx-SLOT yy (CH01)	CABLE	407292		
	BLK AAx PN 03 (J102)	Uxx-SLOT yy (CH02)	CABLE	407292		
	BLK AAx PN 04 (J103)	Uxx-SLOT yy (CH03)	CABLE	407292		
	BLK AAx PN 05 (J104)	Uxx-SLOT yy (COM 0)	CABLE	407292		
	BLK AAx PN 06 (J105)	Uxx-SLOT yy (CH10)	CABLE	407292		
	BLK AAx PN 07 (J106)	Uxx-SLOT yy (CH11)	CABLE	407292		
	BLK AAx PN 08 (J107)	Uxx-SLOT yy (CH12)	CABLE	407292		
	BLK AAx PN 09 (J108)	Uxx-SLOT yy (CH13)	CABLE	407292		
	BLK AAx PN 10 (J109)	Uxx-SLOT yy (COM 1)	CABLE	407292		
	BLK AAx PN 11 (J110)	Uxx-SLOT yy (CH20)	CABLE	407292		
	BLK AAx PN 12 (J111)	Uxx-SLOT yy (CH21)	CABLE	407292		
	BLK AAx PN 13 (J112)	Uxx-SLOT yy (CH22)	CABLE	407292		
	BLK AAx PN 14 (J113)	Uxx-SLOT yy (CH23)	CABLE	407292		
	BLK AAx PN 15 (J114)	Uxx-SLOT yy (COM 2)	CABLE	407292		
	BLK AAx PN 16 (J115)	Uxx-SLOT yy (CH30)	CABLE	407292		
	BLK AAx PN 17 (J116)	Uxx-SLOT yy (CH31)	CABLE	407292		
	BLK AAx PN 18 (J117)	Uxx-SLOT yy (CH32)	CABLE	407292		
	BLK AAx PN 19 (J118)	Uxx-SLOT yy (CH33)	CABLE	407292		
	BLK AAx PN 20 (J119)	Uxx-SLOT yy (COM 3)	CABLE	407292		
	BLK AAx PN 21 (J120)	Uxx-SLOT yy (CH40)	CABLE	407292		
	BLK AAx PN 22 (J121)	Uxx-SLOT yy (CH41)	CABLE	407292		
	BLK AAx PN 23 (J122)	Uxx-SLOT yy (CH42)	CABLE	407292		
	BLK AAx PN 24 (J123)	Uxx-SLOT yy (CH43)	CABLE	407292		
	BLK AAx PN 25 (J124)	Uxx-SLOT yy (COM 4)	CABLE	407292		
RACAL Instruments, Inc., 4 Goodyear St., Irvine, CA 92718						
DOCUMENT TITLE			SIZE	CODE NO.	DOCUMENT NO.	REV
HARNESS ASSEMBLY, 1260-54C, TTI			A	21793	407292	A
			DRN			SHEET 3 of 5

DOC. NO. 407292

ENGINEERING WIRE LIST

WIRE	FROM	TO	TYPE	PART #	WIRE LEN	REFERENCE
	BLK AAx PN 26 (J125)	Uxx-SLOT yy (CH50)	CABLE	407292		
	BLK AAx PN 27 (J126)	Uxx-SLOT yy (CH51)	CABLE	407292		
	BLK AAx PN 28 (J127)	Uxx-SLOT yy (CH52)	CABLE	407292		
	BLK AAx PN 29 (J128)	Uxx-SLOT yy (CH53)	CABLE	407292		
	BLK AAx PN 30 (J129)	Uxx-SLOT yy (COM 5)	CABLE	407292		
<p>This system wirelist serves as a template for incorporating this harness assembly into the overall system wirelist. It does not in any way affect the fabrication of this harness assembly.</p>						
<p style="font-size: small;">RACAL Instruments, Inc., 4 Goodyear St., Irvine, CA 92718</p>						
DOCUMENT TITLE			SIZE	CODE NO.	DOCUMENT NO.	REV
HARNESS ASSEMBLY, 1260-54C, TTI			A	21793	407292	A
			DRN	SHEET 4 of 5		

DOC. NO. 407292

ENGINEERING WIRE LIST

WIRE	FROM	TO	TYPE	PART #	WIRE LEN	REFERENCE
1	J100	CH00	COAX	407263	40"	CHANNEL 00
2	J101	CH01	COAX	407263	40"	CHANNEL 01
3	J102	CH02	COAX	407263	40"	CHANNEL 02
4	J103	CH03	COAX	407263	40"	CHANNEL 03
5	J104	COM 0	COAX	407263	40"	COM 0
6	J105	CH10	COAX	407263	40"	CHANNEL 10
7	J106	CH11	COAX	407263	40"	CHANNEL 11
8	J107	CH12	COAX	407263	40"	CHANNEL 12
9	J108	CH13	COAX	407263	40"	CHANNEL 13
10	J109	COM 1	COAX	407263	40"	COM 1
11	J110	CH20	COAX	407263	40"	CHANNEL 20
12	J111	CH21	COAX	407263	40"	CHANNEL 21
13	J112	CH22	COAX	407263	40"	CHANNEL 22
14	J113	CH23	COAX	407263	40"	CHANNEL 23
15	J114	COM 2	COAX	407263	40"	COM 2
16	J115	CH30	COAX	407263	40"	CHANNEL 30
17	J116	CH31	COAX	407263	40"	CHANNEL 31
18	J117	CH32	COAX	407263	40"	CHANNEL 32
19	J118	CH33	COAX	407263	40"	CHANNEL 33
20	J119	COM 3	COAX	407263	40"	COM 3
21	J120	CH40	COAX	407263	40"	CHANNEL 40
22	J121	CH41	COAX	407263	40"	CHANNEL 41
23	J122	CH42	COAX	407263	40"	CHANNEL 42
24	J123	CH43	COAX	407263	40"	CHANNEL 43
25	J124	COM 4	COAX	407263	40"	COM 4
26	J125	CH50	COAX	407263	40"	CHANNEL 50
27	J126	CH51	COAX	407263	40"	CHANNEL 51
28	J127	CH52	COAX	407263	40"	CHANNEL 52
29	J128	CH53	COAX	407263	40"	CHANNEL 53
30	J129	COM 5	COAX	407263	40"	COM 5

DOC. NO. 407292

RACAL Instruments, Inc., 4 Goodyear St., Irvine, CA 92718

DOCUMENT TITLE	SIZE	CODE NO.	DOCUMENT NO.	REV
HARNESS ASSEMBLY, 1260-54C, TTI	A	21793	407292	A
	DRN		SHEET 5 of 5	

Chapter 7

PRODUCT SUPPORT

Product Support

Racal Instruments has a complete Service and Parts Department. If you need technical assistance or should it be necessary to return your product for repair or calibration, call 1-800-722-3262. If parts are required to repair the product at your facility, call 1-949-859-8999 and ask for the Parts Department.

When sending your instrument in for repair, complete the form in the back of this manual.

For worldwide support and the office closes to your facility, refer to the Support Offices section on the following page.

Reshipment Instructions

Use the original packing material when returning the 1260-54 to Racal Instruments for calibration or servicing. The original shipping crate and associated packaging material will provide the necessary protection for safe reshipment.

If the original packing material is unavailable, contact Racal Instruments Customer Service for information.

Support Offices

Racal Instruments, Inc.

4 Goodyear St., Irvine, CA 92618-2002
Tel: (800) RACAL-ATE, (800) 722-2528,
(949) 859-8999; FAX: (949) 859-7139

Racal Instruments, Ltd.

480 Bath Road, Slough, Berkshire, SL1 6BE, United Kingdom
Tel: +44 (0) 1628 604455; FAX: +44 (0) 1628 662017

Racal Systems Electronique S.A.

18 Avenue Dutartre, 78150 LeChesnay, France
Tel: +33 (1) 3923 2222; FAX: +33 (1) 3923 2225

Racal Systems Elettronica s.r.l.

Strada 2-Palazzo C4, 20090 Milanofiori Assago, Milan, Italy
Tel: +39 (0)2 5750 1796; FAX +39 (0)2 5750 1828

Racal Elektronik System GmbH.

Technologiepark Bergisch Gladbach, Friedrich-Ebert-Strasse,
D-51429 Bergisch Gladbach, Germany
Tel.: +49 2204 8442 00; FAX: +49 2204 8442 19

Racal Australia Pty. Ltd.

3 Powells Road, Brookvale, NSW 2100, Australia
Tel: +612 9936 7000, FAX: +612 9936 7036

Racal Electronics Pte. Ltd.

26 Ayer Rajah Crescent, 04-06/07 Ayer Rajah Industrial Estate,
Singapore 0513.
Tel: +65 7792200, FAX: +65 7785400

Racal Instruments, Ltd.

Unit 5, 25F., Mega Trade Center, No 1, Mei Wan Road, Tsuen
Wan, Hong Kong, PRC
Tel: +852 2405 5500, FAX: +852 2416 4335